

Product Information**UR1- / UR2-015..050V M / K****Flow Switch
UR1 / UR2-...V**

- Low pressure loss
- Compact design
- Soldered/welded connection

Characteristics

The devices function via the principle of a spring-supported paddle, and the magnetic triggering of a reed switch.

Technical data

Switch	reed switch	
Nominal width	DN 15..80	
Process connection	soldered/welded nozzle (further process connections available on request)	
Switching range	5..174 l/min	for details see table "Ranges"
Q_{max.}	to 600 l/min	
Tolerance	±15 % of full scale value	
Pressure	Brass	PN 25 bar (UR1)
	Stainless steel	
	PVC	PN 10 bar (UR2)
	PPS	
Medium temperature	-20..+110 °C (optionally 150 °C)	
Ambient temperature	-20..+70 °C	
Media	water (oils, gases and aggressive media available on request)	
For electrical data see "UR1 Brass switching unit" or "UR1 Plastic switching unit"	see "UR1 Brass switching unit" or "UR1 Plastic switching unit"	
Materials medium-contact	<i>Brass construction:</i>	<i>Stainless steel construction:</i>
	CW617N nickelled, CW614N, 1.4310, 1.4301, hard ferrite, NBR	1.4305, 1.4571, 1.4310, 1.4310, hard ferrite PTFE-coated, FKM
	<i>Optional:</i> Body made from POM (PN 10) Body made from PPS (PN 10)	

Non-medium-contact materials	see "UR1 Brass switching unit" or "UR1 Plastic switching unit"
Weight	see table "Dimensions and weights"
Installation location	Standard: horizontal inwards flow; switching unit not recommended underneath; other installation positions are possible; the installation position affects the switching point and range.

UR1 Brass switching unit

Wiring	normally open (n.o.) or normally closed (n.c.), no. 0.225
Switching voltage	max. 230 V AC
Switching current	max. 1 A
Switching cap.	max. 50 VA
Protection class	1 - PE connection
Ingress protection	IP 65
Electrical connection	cabl 1.5 m, optionally for round plug connector M12x1, 4-pole
Materials, non-medium-contact	CW614N, nickelled, CW614N, NBR, PVC, POM

UR2 Plastic switching unit

Wiring	Normally open (n.o.) 0.446 Normally closed (n.c.) 0.447
Switching voltage	max. 230 V AC
Switching current	max. 1 A
Switching cap.	max. 50 VA
Protection class	2 - Safety insulation
Ingress protection	IP 65
Electrical connection	cabl 1.5 m
Materials, non-medium-contact	PA, PVC, POM

Product Information

UR1- / UR2-015..050V M / K

Ranges

Details in the table correspond to horizontal inwards flow with decreasing flow rate. UR2 (Plastic switching unit) is adjusted in the factory; please specify switching value.

DN	Switching range l/min H ₂ O	Types	Q _{max.} recommended
DN 15	5.0 - 6.5	UR.-015V.	20
DN 20	10.0 - 15.5		40
DN 25	11.0 - 13.0	UR.-025V.	80
DN 32	26.0 - 33.0		100
DN 40	37.0 - 42.5		150
DN 50	47.5 - 60.0	UR.-050V.	200
DN 65	95.0 - 117.0		400
DN 80	147.0 - 179.0		600

Special ranges are available.

Dimensions and weights

DN	Types	H	D	A	B	Weight kg	
						UR1	UR2
DN 15..20	UR.-015V.	18.0	13	-	-	0.25	0.20
DN 25..50	UR.-025V.	27.5	-	12	16		
DN 50..80	UR.-050V.	42.0			19		

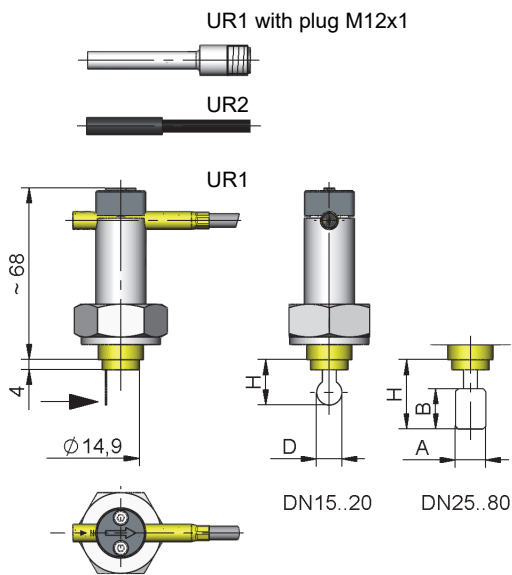

Handling and operation

Note

- Include straight calming section of 5 x DN in inlet and outlet
- If the media are dirty, install a filter (use magnetic filter for ferritic components).
- It must be ensured that the values given for voltage, current, and power are not exceeded.
- When switched on, a load must be connected in series.
- The electrical details apply to ohmic loads. Capacitive, inductive and lamp loads must be operated using a protective circuit.

Adjustment

UR1 - loosen bolts, push the switching current tube into the desired position. Retighten the bolts.
Normally closed (n.c.) or normally open (n.o.) as per table "Technical data"

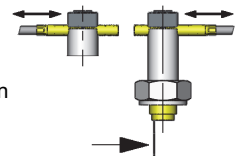

Ordering code

1. 2. 3. 4. 5.
UR - V

○=Option

1. Switching unit	
1	brass
2	○ plastic (already adjusted, specify switching value and normally closed (n.c.) or normally open (n.o.))
2. Nominal width	
015	DN 15..25
025	DN 25..40
050	DN 50..80
3. Process connection	
V	soldered/welded nozzle
4. Connection material	
M	brass
K	stainless steel
5. Switching unit options	
A	for switching unit ATEX A-U1.1 The switching head is ordered in addition.
S	○ for round plug connector M12x1, 4-pole

Options

- Switching ranges for oil or gas
- Special quantity
- Adhesive PVC fitting

Ordering information

- Specify direction of flow, medium, and switching range, UR1 or switching value UR2.
- For UR2 specify normally closed (n.c.) or normally open (n.o.).
- For oils, state viscosity, temperature and designation (e.g. ISO VG 68) (enquire about range).
- For gases, state pressure (relative or absolute), temperature and medium (e.g. air) (enquire about range).