

**Product Information**

**CRE-025HM / K**

**Flow Switch CRE**



- Can be used from nominal width DN 25..200
- Suitable for media with ferritic particles

**Characteristics**

The devices function via the principle of a paddle supported by a metal bellows, and the triggering of a micro switch.

**Technical data**

<b>Switch</b>	micro switch	
<b>Nominal width</b>	DN 25..200	
<b>Process connection</b>	male thread R 1 "	
<b>Switching range</b>	0.19..165.7 m <sup>3</sup> /h	for details see table "Ranges"
<b>Q<sub>max.</sub></b>	up to 240 m <sup>3</sup> /h	
<b>Tolerance</b>	±15 % of full scale value	
<b>Pressure resistance</b>	brass construction PN 8 bar , reduced switching range PN 5 bar	stainless steel construction PN 13 bar , reduced switching range PN 5 bar
<b>Medium temperature</b>	-20..+120 °C	
<b>Ambient temperature</b>	-20..+85 °C	
<b>Media</b>	water (oils and aggressive media available on request)	
<b>Wiring</b>	changeover no. 0.374 	
<b>Switching voltage</b>	250 V AC	
<b>Switching current</b>	15(8) A	
<b>Protection class</b>	1 - PE connection	
<b>Ingress protection</b>	IP 65	
<b>Electrical connection</b>	cable screw gland M16x1.5	
<b>Materials medium-contact</b>	Brass construction: CW614N, 1.4571, Tombak	Stainless steel construction: 1.4571
<b>Non-medium-contact materials</b>	ABS	
<b>Weight</b>	Brass construction: Stainless steel construction:	0.95 kg 1.1 kg

<b>Installation location</b>	Standard: horizontal inwards flow; switching unit not recommended underneath; other installation positions are possible; the installation position affects the switching point and range.
------------------------------	---

**Ranges**

Details in the table correspond to horizontal inwards flow with decreasing flow rate.

● = Standard ○ = Option for reduced switching range

DN	Switching range m <sup>3</sup> /h H <sub>2</sub> O				Q <sub>max.</sub> recommended
	Paddle 1	Paddle 1,2*	Paddle 1,2,3*	Paddle 1,2,3,4*	
25	○ 0.19 - 1.0 ● 0.55 - 2.0				3.6
32	○ 0.24 - 1.4 ● 0.82 - 2.8				6.0
40	○ 0.50 - 1.9 ● 1.10 - 4.0				9.0
50	○ ●	0.9 - 3.6 2.1 - 7.3			15.0
65	○ ●	1.2 - 4.9 2.8 - 9.8			24.0
80	○ ●		2.1 - 7.4 4.0 - 13.8		36.0
100	○ ●		4.9 - 17.1 10.4 - 32.0	3.3 - 11.6 7.0 - 21.7	60.0
125	○ ●		9.7 - 34.0 20.8 - 63.5	5.0 - 17.5 10.7 - 33.3	90.0
150	○ ●		13.6 - 47.6 29.2 - 89.1	6.1 - 21.4 13.1 - 39.9	120.0
200	○ ●		25.7 - 90.1 72.6 - 165.7	21.7 - 55.3 38.6 - 90.8	240.0

\*must be used together

**Dimensions**

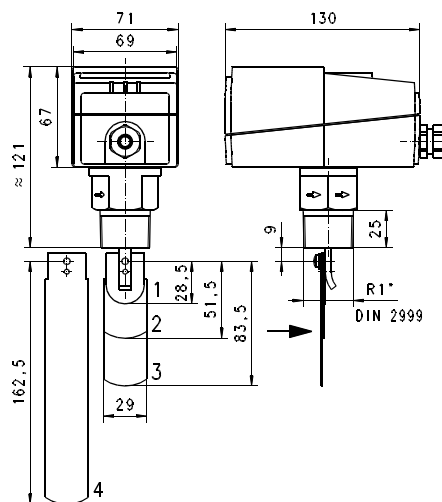

Adapt paddle 1 for DN 25.  
From DN 100, adapt paddle 4:  
DN 100 Paddle length 92  
DN 125 Paddle length 117  
DN 150 Paddle length 143  
from DN 175 unshortened

**Product Information**

**Handling and operation**

**Note**

- Attention! Paddle fixing unsecured. For critical conditions (e.g. vibration), fit a bolted fixing.
- Include straight calming section of 10 x DN in inlet and outlet
- If the media are dirty, install a filter.
- It must be ensured that the values given for voltage, current, and power are not exceeded.
- When switched on, a load must be connected in series.
- The electrical details apply to ohmic loads.  
Capacitive and inductive loads must be operated using a protective circuit.

**Loosen adjustment**

Screw, and remove hood; set the desired switching value using the adjustment screw, and refasten the hood.

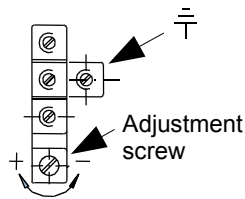

**Installation recommendation**

Use a tube with standard wall thickness as per DIN 2448

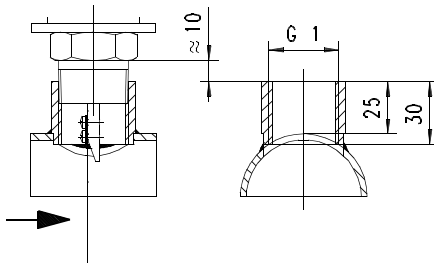

**Ordering code**

1. 2. 3. 4.  
**CRE - 025H**  **S**

○=Option

<b>1. Process connection</b>	
025H	threaded connection DN 25 - R 1 "
<b>2. Connection material</b>	
M	brass
K	stainless steel
<b>3. Cable screw gland</b>	
S	to the side
<b>4. Switching range</b>	
R	<input type="checkbox"/> reduced

**Options**

- TÜV certification  
 CRE-025HMS / CRE-025HKS TÜV.SW.14-028  
 CRE-025HMSR / CRE-025HKS SR TÜV.SW.14-029
- Switching ranges for oil
- Special values



**Ordering information**

- Specify direction of flow, medium, and switching range.
- For oils, state viscosity, temperature and designation (e.g. ISO VG 68) (enquire about range).