

**Multifunctional relay  
for single low-action and snap-action contacts  
with indication of switching condition**

**MSR 010**

**Range of application**

The multifunctional relays of the MSR 010 series are contact protection relays to connect single contacts. These increase the switching safety and the switching capacity of electro-mechanical limit value switches and reduce the contact load of same. Any unintended switching operations of the limit value switches caused by vibration are largely reduced in a fail-delay time. Multifunctional relays are absolutely recommended for use with limit value switches immersed in oil.

**Regulations**

Multifunctional relays are apparatus to be built in, or electronic operating material for use in closed electrical industrial plants, and must be installed exclusively by electrical experts or persons trained in electronics. Any mistakes made by inappropriate handling are not subject to any guarantee.

Multifunctional relays comply with the following regulations:

- EN 50178 Electrical safety
- EN 61000.6.2 Resistance to interference
- EN 61000.6.3 Emission of interfering impulses
- EN 60947-5-1 Low voltage switching apparatus

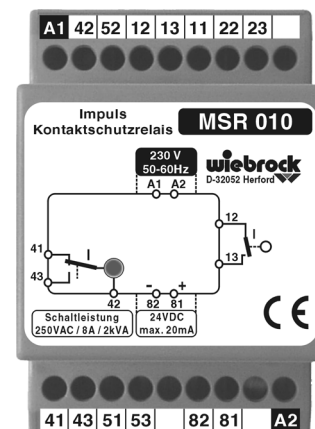

Technical data**		MSR 010 relay output basic version	MSR 010-E electronic output PNP for SPS input	MSR 010-L reed relay output for small switching operations	MSR 010-N relay output control voltage > 100 V for low action contacts
	Terminals				
<b>Auxiliary energy</b> Rated operational voltage Ue	A1-A2	230 V AC 50-60 Hz +6...-10% resp. available with the following supply voltages 115 V AC 50-60 Hz +6...-10% 24 V AC 50-60 Hz +6...-10% 24 V DC +15...-10% typ. 6 VA (1,5 VA/W)*			230 V AC 50-60 Hz +6...-10% resp. available with the following supply voltage 115 V AC 50-60 Hz +6...-10%
Power consumption					typ. 6 VA
<b>Control signals</b> Control voltage	12	35-40 V DC pulses (24 V DC pulses)*			Positiv semi sinus wave of the auxiliary energy above 50 kΩ
Pulse/pause ratio		0.5 ms / 50 ms ±20%			9,7 V DC ±10%
Switching threshold	13	9,7 V DC ±10%			3,3 kΩ, 100 nF ±20%
Input impedance	13	3,3 kΩ, 100 nF ±20%			max. 40 kΩ, 47 nF
Wire and contact resistance	12-13	max. 4,7 kΩ, 47 nF (3,0 kΩ, 47 nF)*			
<b>Outputs</b> Pick-up and fall delay time	42-41-43	1 relay (change over contact) 10 ms/450 ms ±20% +50 ms	1 electronic output PNP 41(+), 43(-) 0,5 ms/450 ms ±20% +50 ms	1 reedrelay (make contact) 1,5 ms/450 ms ±20% +50 ms	1 relay (change over contact) 10 ms/450 ms ±20% +50 ms
Contact material		AgCdO resp. AgNi+Au			AgCdO resp. AgNi+Au
Breaking capacity		max. 250 V AC/8 A min. 24 V DC/0,1 A	24 V DC max. 50 mA Conditionally resistant Freewheeling diode built in	max. 100 V/0,5 A/10 W(VA) min. 1 V/1 mA	max. 250 V AC/8 A min. 24 V DC/0,1 A
Rated operational current Ie		Utilization category AC1 250 V/8 A AC13 250 V/3 A DC1 250 V/0,3 A DC13 250 V/0,1 A		Electric strength Coil / contact 350 Veff	Utilization category AC1 250 V/8 A AC13 250 V/3 A DC1 250 V/0,3 A DC13 250 V/0,1 A
Short-circuit protection device		F 10 A			F 10 A
Max. short circuit current		< 100 A			< 100 A
<b>Voltage output</b> Power output	82(-), 81(+)	only for external apparatus, e.g. sensor supply or LED displays			
Max. short circuit current		24 V DC ±10% I <sub>max</sub> 20 mA Conditionally resistant to short-circuit			
<b>Range of application</b> Rated insulation voltage		250 V AC			
Overvoltage category		III			
Contamination level	EN 50178	2			
Protection type	EN 60529	IP 20			
Temperature range		0...70 °C			
Material of casing		Polyamide 6.6, colour red/black			
<b>Annotation</b>		*) The data refer to auxiliary energy/rating voltage 24 V AC/DC **) Alteration on request			

**Accessories**

(re. catalogue page K 11-00.020)

Protecting casing IP 65 (IEC 529)

Adapter for individual fastening

Standard rail acc. to DIN 50022

**Connection, fastening and dimensions**

AWG	Nm	mm <sup>2</sup>	mm <sup>2</sup>
20...14	0.5 max	1x(0,5...2,5)	1x(0,5...2,5)
		2x(0,5...1,5)	2x(0,5...1,5)

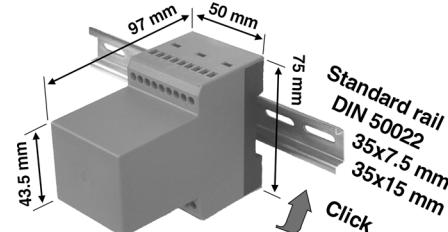

# Multifunctional relay for single low-action and snap-action contacts with indication of switching condition

## Versions

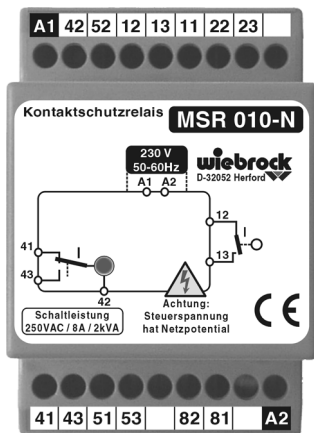
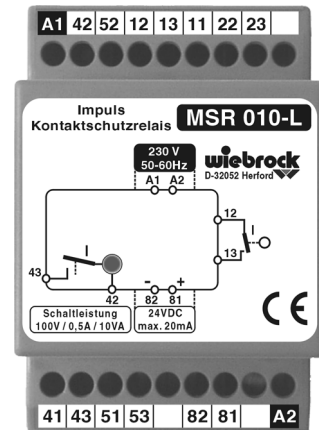
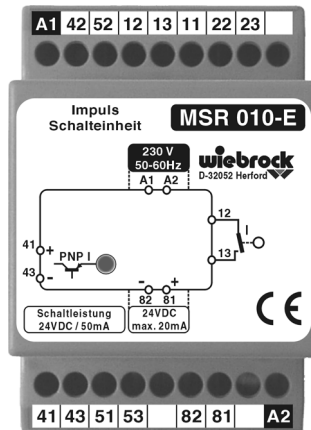
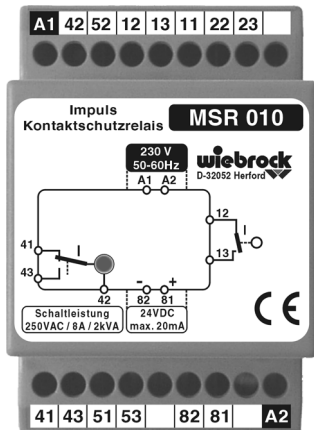

### Important notice

If desired, it is possible to interconnect several relays (MSR 010 and MSR 020). In this case one control output (terminal 12 or 22) may operate a maximum of 4 control inputs (terminal 13 or 23). In this way, the permissible contact transition resistance is reduced to 2 kOhm at maximum (1 kOhm with an auxiliary energy of 24 V AC/DC). A link between the control outputs is not necessary.

If one control output is meant to operate the inputs of several MSR relays, it will be imperative to provide a uniform reference potential. In this case, the terminals 82 of the MSR relays must be connected. Example of connection: re. catalogue page K11-05.010 (for triple and quadruple contacts).

### Important notice for MSR xxx-N

The control circuit of the MSRxxx-N is not galvanically separated from the mains. If one control output is meant to operate the control inputs of several MSRxxx-N, all MSRxxx-N relays must be supplied in equiphase by one and the same voltage (A1 on A1 and A2 on A2), and the control outputs of the respective control inputs must be inter-connected. Special attention must be paid to the control outputs of the new MSRxxx-N version provided with a CE symbol. These should not be wired together with the previous MSRxxx-N version which is not marked by the CE symbol.

## Example of connection MSR 010

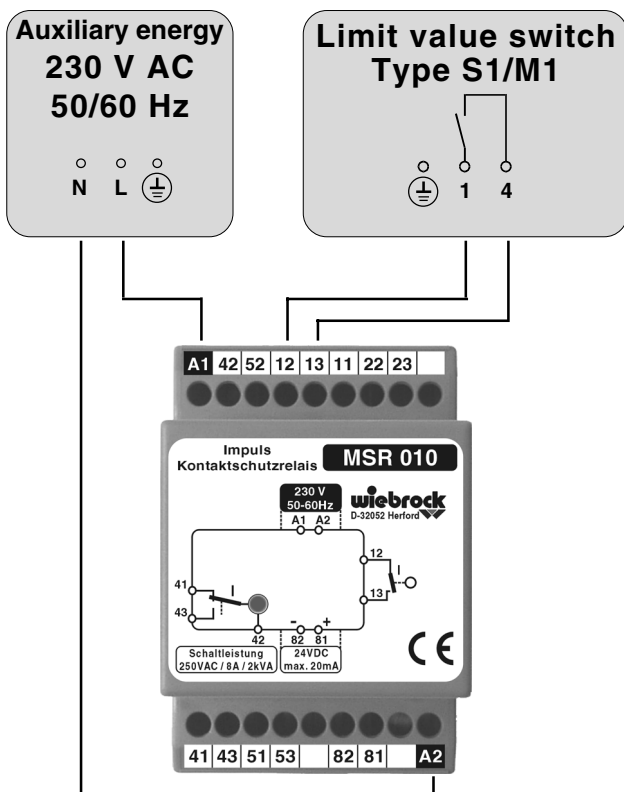

### Functional discription

The multifunctional relay is supplied with the respective voltage via terminals A1 and A2. When the supply voltage has been switched in (the connected limit value switch is not operated, contact 1 - 4 is open) the potential free change-over device of the MSR-relay is non-operative (re. type plate). By operating the limit value switch (contact 1-4 is closed) the contact at the change-over device is closed. When the supply voltage is interrupted, the potential free change-over device of the MSR relay returns to its inoperative condition.

**Multifunctional relay  
for double low-action and snap-action contacts type S-21/M-21 (interval function)  
with indication of switching condition**

**MSR 011**

**Range of application**

The multifunctional relays of the MSR 011 series are the bistable execution for the connection of double contacts S-21/M-21 (interval). In this way for instance, the MSR 011 saves the lower contact condition once reached (min.) on a intermediary basis until the upper contact (max.) has once clearly confirmed. These increase the switching safety and the switching capacity of electro-mechanical limit value switches and reduce the contact load of same.  
Multifunctional relays are absolutely recommended for use with limit value switches immersed in oil.

**Regulations**

**Multifunctional relays are apparatus to be built in, or electronic operating material for use in closed electrical industrial plants, and must be installed exclusively by electrical experts or persons trained in electronics. Any mistakes made by inappropriate handling are not subject to any guarantee.**

Multifunctional relays comply with the following regulations:

- EN 50178 Electrical safety
- EN 61000.6.2 Resistance to interference
- EN 61000.6.3 Emission of interfering impulses
- EN 60947-5-1 Low voltage switching apparatus

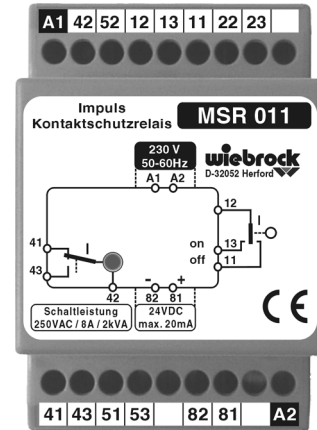

Technical data**		MSR 011 relay output basic version	MSR 011-E electronic output PNP for SPS input	MSR 011-L reed relay output for small switching operations	MSR 011-N relay output control voltage > 100 V for low action contacts
	Terminals				
<b>Auxiliary energy</b> Rated operational voltage Ue	A1-A2	230 V AC 50-60 Hz +6...-10% resp. available with the following supply voltages 115 V AC 50-60 Hz +6...-10% 24 V AC 50-60 Hz +6...-10% 24 V DC +15...-10% typ. 6 VA (1,5 VA/W)*			230 V AC 50-60 Hz +6...-10% resp. available with the following supply voltages 115 V AC 50-60 Hz +6...-10%
Power consumption					typ. 6 VA
<b>Control signals</b> Control voltage	12	35-40 V DC pulses (24 V DC pulses)* 0,5 ms / 50 ms ±20%			Positiv semi sinus wave of the auxiliary energy above 50 kΩ
Pulse/pause ratio		9,7 V DC ±10%			9,7 V DC ±10%
Switching threshold	13, 11	3,3 kΩ, 100 nF ±20%			3,3 kΩ, 100 nF ±20%
Input impedance	13, 11	max. 4,7 kΩ, 47 nF (3,0 kΩ, 47 nF)*			max. 40 kΩ, 47 nF
Wire and contact resistance	12-13, 22-11				
<b>Outputs</b> Pick-up and fall delay time	42-41-43	1 relay (change over contact) 10 ms/450 ms ±20% +50 ms	1 electronic output PNP 41(+), 43(-) 0,5 ms/450 ms ±20% +50 ms	1 reedrelay (make contact) 1,5 ms/450 ms ±20% +50 ms	1 relay (change over contact) 10 ms/450 ms ±20% +50 ms
Contact material		AgCdO resp. AgNi+Au			AgCdO resp. AgNi+Au
Breaking capacity		max. 250 V AC/8 A min. 24 V DC/0,1 A	24 V DC max. 50 mA Conditionally resistant Freewheeling diode built in	max. 100 V/0,5 A/10 W(VA) min. 1 V/1 mA Electric strength Coil / contact 350 Veff	max. 250 V AC/8 A min. 24 V DC/0,1 A
Rated operational current Ie		Utilization category AC1 250 V/8 A AC13 250 V/3 A DC1 250 V/0,3 A DC13 250 V/0,1 A			Utilization category AC1 250 V/8 A AC13 250 V/3 A DC1 250 V/0,3 A DC13 250 V/0,1 A
Short-circuit protection device		F 10 A < 100 A			F 10 A < 100 A
Max. short circuit current					
<b>Voltage output</b> Power output	82(-), 81(+)	only for external apparatus, e.g. sensor supply or LED displays 24 V DC ±10% I <sub>max</sub> 20 mA Conditionally resistant to short-circuit			
Max. short circuit current					
<b>Range of application</b> Rated insulation voltage		250 V AC			
Overvoltage category		III			
Contamination level	EN 50178	2			
Protection type	EN 60529	IP 20			
Temperature range		0...70 °C			
Material of casing		Polyamide 6.6, colour red/black			
<b>Annotation</b>		*) The data refer to auxiliary energy/rating voltage 24 V AC/DC **) Alteration on request			

**Accessories**

(re. catalogue page K 11-00.020)

Protecting casing IP 65 (IEC 529)

Adapter for individual fastening

Standard rail acc. to DIN 50022

**Connection, fastening and dimensions**

AWG	Nm	mm <sup>2</sup>	mm <sup>2</sup>
20...14	0.5 max	1x(0,5...2,5)	1x(0,5...2,5)
		2x(0,5...1,5)	2x(0,5...1,5)

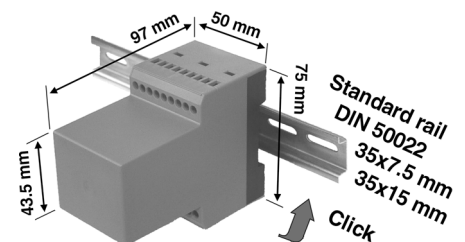

03.2005 Errors excepted. Subject to alteration without notice.

# Multifunctional relay for double low-action and snap-action contacts type S-21/M-21 (interval function) with indication of switching condition

## Versions

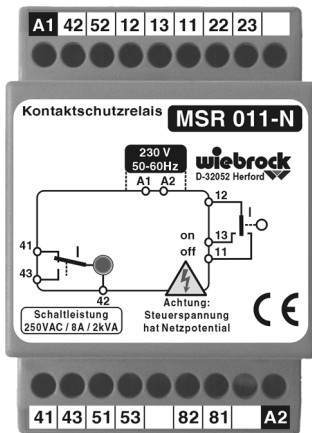
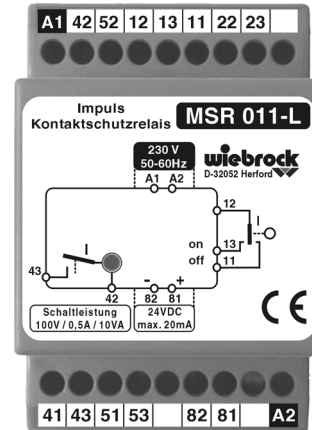
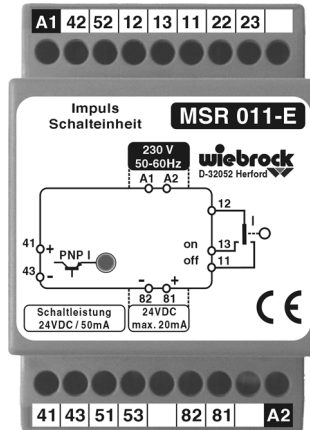
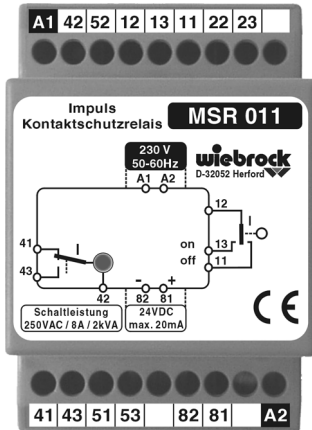

## Example of connection MSR 011

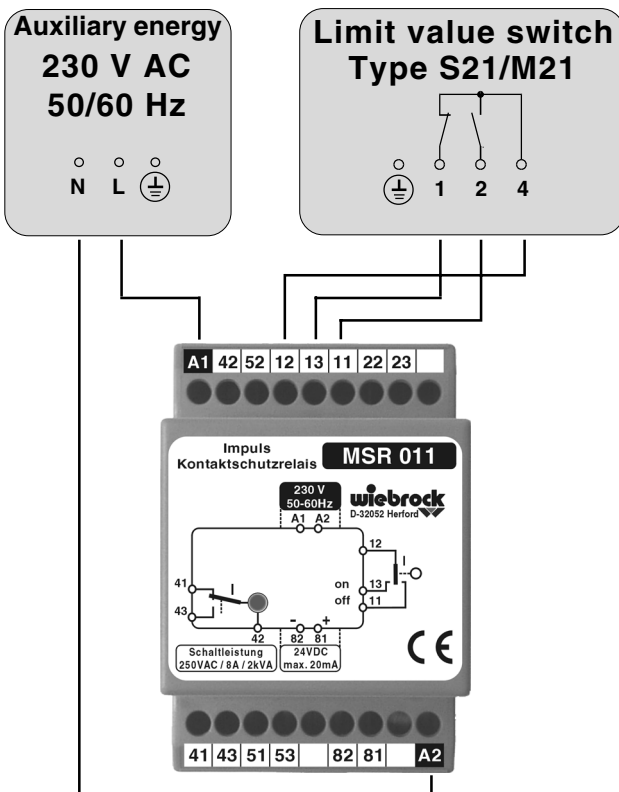

## Functional description

The multifunctional relay is supplied with the respective voltage via terminals A1 and A2. When the supply voltage has been switched on (the connected limit value switch is not operated, contact 1-4 is closed, contact 2-4 is open) the contacts are operated at the potential free change-over device.

If contact 1-4 is opened by the limit value switch (contact 2-4 remains open), the contacts at the change-over device stay closed. Only when contact 2-4 is closed (contact 1-4 has no influence on the switching behaviour any longer) the potential-free change-over device of the MSR relay returns to its inoperative condition (re. type plate).

If contact 2-4 of the limit value switch opens again, the contacts at the change-over device remain inoperative. If contacts 1-4 close, the contacts at the change-over device are operated again (interval operation).

This is a bistable execution, intermediately memorising the switching condition of one contact during the interval until the other contact is operated (no permanent memorising).

When the supply voltage is interrupted, the potential free change-over device of the MSR series returns to its inoperative condition. If both contacts are closed, the preferential situation will depend on the respective transitional resistances and is considered as not defined in this case.

# Multifunctional relay for double low-action and snap-action contacts with indication of switching condition

**MSR 020**

## Range of application

The multifunctional relays of the MSR 020 series are contact protection relays to connect double contacts. These increase the switching safety and the switching capacity of electro-mechanical limit value switches and reduce the contact load of same. Any unintended switching operations of the limit value switches caused by vibration are largely reduced in a fail-delay time. Multifunctional relays are absolutely recommended for use with limit value switches immersed in oil.

## Regulations

Multifunctional relays are apparatus to be built in, or electronic operating material for use in closed electrical industrial plants, and must be installed exclusively by electrical experts or persons trained in electronics. Any mistakes made by inappropriate handling are not subject to any guarantee.

Multifunctional relays comply with the following regulations:

- EN 50178 Electrical safety
- EN 61000.6.2 Resistance to interference
- EN 61000.6.3 Emission of interfering impulses
- EN 60947-5-1 Low voltage switching apparatus

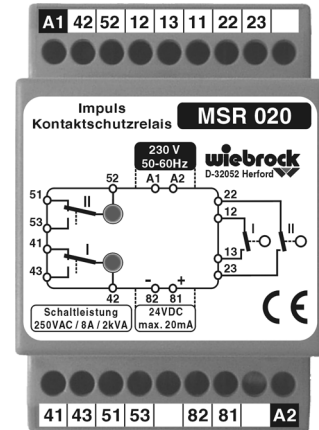

Technical data**		MSR 020 relay output basic version	MSR 020-E electronic output PNP for SPS input	MSR 020-L reed relay output for small switching operations	MSR 020-N relay output control voltage > 100 V for low action contacts
	Terminals				
<b>Auxiliary energy</b> Rated operational voltage Ue	A1-A2	230 V AC 50-60 Hz +6...-10% resp. available with the following supply voltages 115 V AC 50-60 Hz +6...-10% 24 V AC 50-60 Hz +6...-10% 24 V DC +15...-10% typ. 6 VA (1,5 VA/W)*			230 V AC 50-60 Hz +6.-10% resp. available with the following supply voltage 115 V AC 50-60 Hz +6.-10%
Power consumption					typ. 6 VA
<b>Control signals</b> Control voltage	12, 22	35-40 V DC pulses (24 V DC pulses)*			Positiv semi sinus wave of the auxiliary energy above 50 kΩ
Pulse/pause ratio		0.5 ms / 50 ms ±20%			9,7 V DC ±10%
Switching threshold	13, 23	9,7 V DC ±10%			3,3 kΩ, 100 nF ±20%
Input impedance	13, 23	3,3 kΩ, 100 nF ±20%			max. 40 kΩ, 47 nF
Wire and contact resistance	12-13, 22-23	max. 4,7 kΩ, 47 nF (3,0 kΩ, 47 nF)*			
<b>Outputs</b>	42-41-43 52-51-53	2 relays (change over contact) 10 ms/450 ms ±20% +50 ms AgCdO resp. AgNi+Au max. 250 V AC/8 A min. 24 V DC/0,1 A Utilization category AC1 250 V/8 A AC13 250 V/3 A DC1 250 V/0,3 A DC13 250 V/0,1 A F 10 A < 100 A	2 electronic outputs PNP 41(+), 43(-) 51(+), 53(-) 0,5 ms/450 ms ±20% +50 ms 24 V DC max. 50 mA Conditionally resistant Freewheeling diode built in	2 reedrelays (make contact) 1,5 ms/450 ms ±20% +50 ms max. 100 V/0,5 A/10 W(VA) min. 1 V/1 mA Electric strength Coil / contact 350 Veff	2 relays (change over contact) 10 ms/450 ms ±20% +50 ms AgCdO resp. AgNi+Au max. 250 V AC/8 A min. 24 V DC/0,1 A Utilization category AC1 250 V/8 A AC13 250 V/3 A DC1 250 V/0,3 A DC13 250 V/0,1 A F 10 A < 100 A
Pick-up and fall delay time					
Contact material					
Breaking capacity					
Rated operational current Ie					
Short-circuit protection device					
Max. short circuit current					
<b>Voltage output</b> Power output	82(-), 81(+)	only for external apparatus, e.g. sensor supply or LED displays			
Max. short circuit current		24 V DC ±10% I <sub>max</sub> 20 mA Conditionally resistant to short-circuit			
<b>Range of application</b> Rated insulation voltage		250 V AC			
Overvoltage category		III			
Contamination level	EN 50178	2			
Protection type	EN 60529	IP 20			
Temperature range		0...70 °C			
Material of casing		Polyamide 6.6, colour red/black			
<b>Annotation</b>		*) The data refer to auxiliary energy/rating voltage 24 V AC/DC **) Alteration on request			

## Accessories

(re. catalogue page K 11-00.020)

Protecting casing IP 65 (IEC 529)

Adapter for individual fastening

Standard rail acc. to DIN 50022

## Connection, fastening and dimensions

AWG	Nm	mm <sup>2</sup>	mm <sup>2</sup>
20...14	0.5 max	1x(0,5...2,5)	1x(0,5...2,5)
		2x(0,5...1,5)	2x(0,5...1,5)

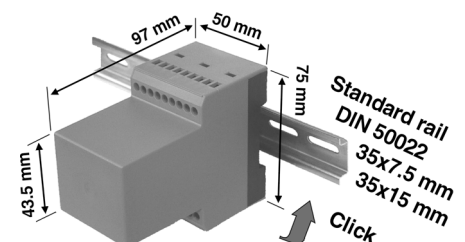

# Multifunctional relay for double low-action and snap-action contacts with indication of switching condition

## Versions

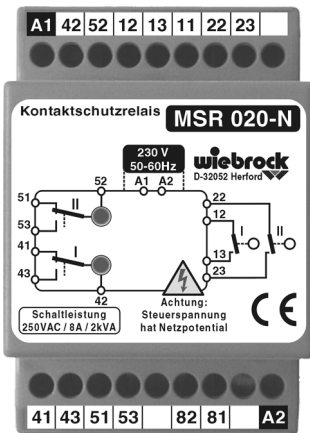
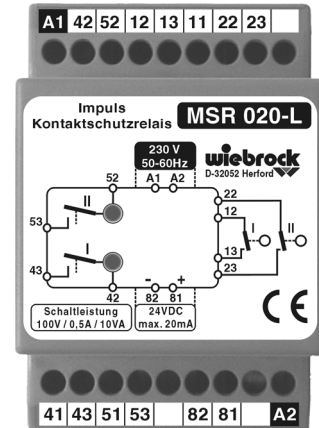
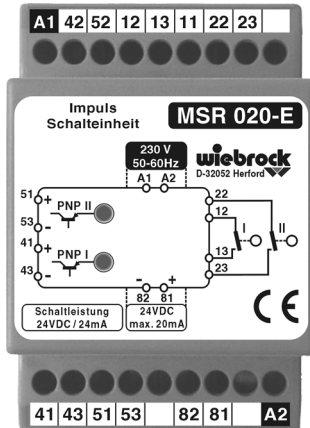
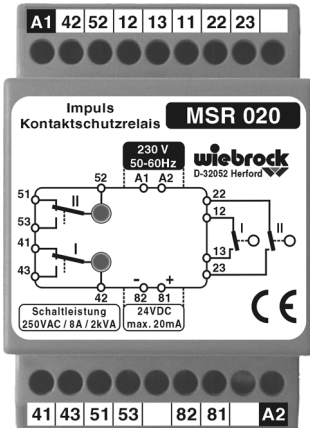

### Important notice

If desired, it is possible to interconnect several relays (MSR 010 and MSR 020). In this case one control output (terminal 12 or 22) may operate a maximum of 4 control inputs (terminal 13 or 23). In this way, the permissible contact transition resistance is reduced to 2 kOhm at maximum (1 kOhm with an auxiliary energy of 24 V AC/DC). A link between the control outputs is not necessary.

If one control output is meant to operate the inputs of several MSR relays, it will be imperative to provide a uniform reference potential. In this case, the terminals 82 of the MSR relays must be connected. Example of connection: re. catalogue page K11-05.010 (for triple and quadruple contacts).

### Important notice for MSR xxx-N

The control circuit of the MSRxxx-N is not galvanically separated from the mains. If one control output is meant to operate the control inputs of several MSRxxx-N, all MSRxxx-N relays must be supplied in equiphase by one and the same voltage (A1 on A1 and A2 on A2), and the control outputs of the respective control inputs must be inter-connected. Special attention must be paid to the control outputs of the new MSRxxx-N version provided with a CE symbol. These should not be wired together with the previous MSRxxx-N version which is not marked by the CE symbol.

## Example of connection MSR 020

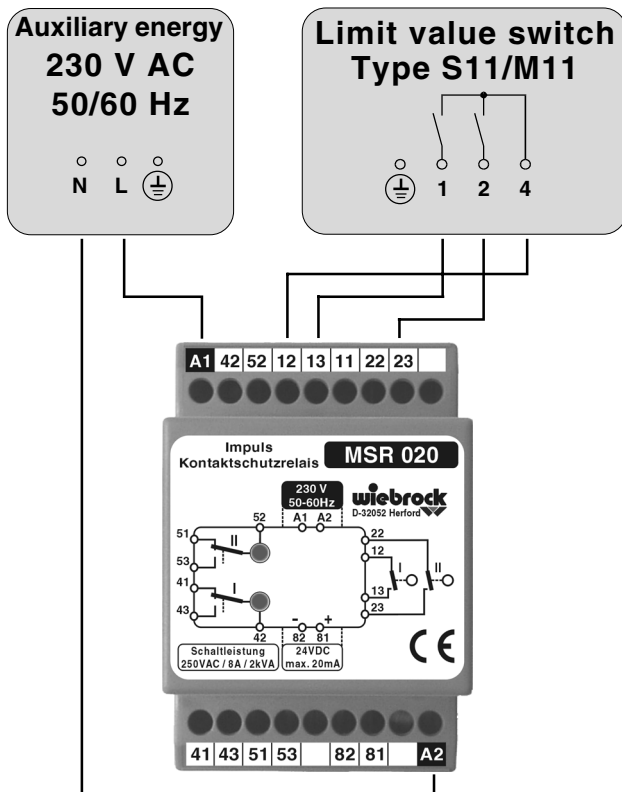

### Functional discription

The multifunctional relay is supplied with the respective voltage via terminals A1 and A2. When the supply voltage has been switched in (the connected limit value switch is not operated, contact 1 - 4 resp. 2-4 is open) the potential free change-over device of the MSR-relay is non-operative (re. type plate). By operating the limit value switch (contact 1-4 resp. 2-4 is closed) the contact at the change-over device is closed. When the supply voltage is interrupted, the potential free change-over device of the MSR relay returns to its inoperative condition.