

TEMPERATURE RECORDER SERIES ERT/100

GENERAL DESCRIPTION

The inert gas temperature ERT/100 recorder can be installed anywhere thanks to its small size, even on portable refrigerators.

It is used in all industry sectors and in particular in the food, pharmaceutical and refrigeration industries.



DIMENSIONS

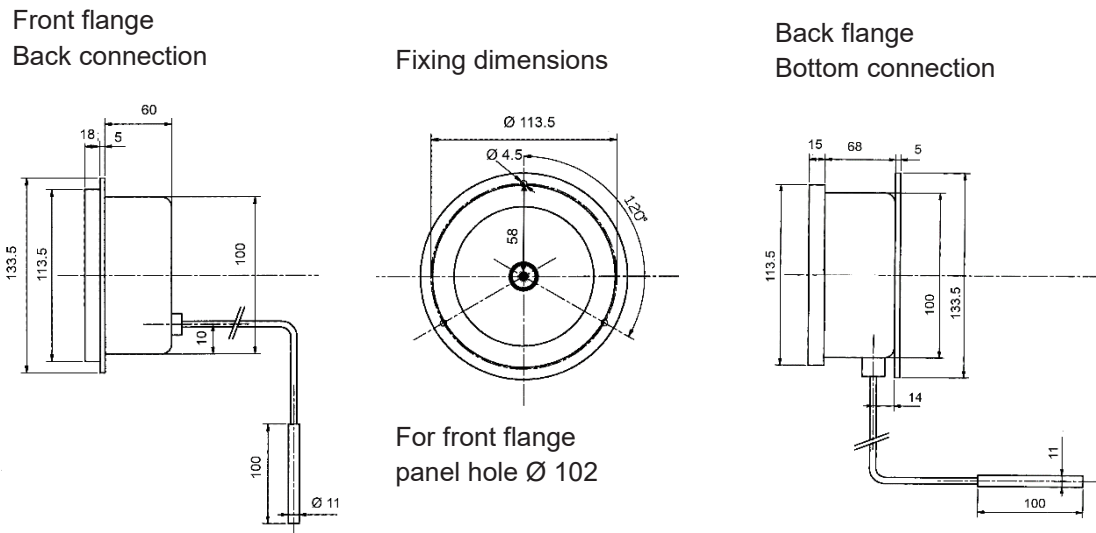

Dimensions in mm

TECHNICAL SPECIFICATIONS

Measuring element: heat-treated Bourdon spring

Capillary: AISI 316 stainless steel

Bulb: AISI 316 stainless steel. Ø 11 mm as standard. Sensing part 100 mm

Case and ring: stainless steel, with bayonet ring closure

Protection degree: IP54 according to IEC 529

Scale range: from -100°C up to 500°C

Accuracy: Class 2 according to EN 13190

Ambient temperature: -20°C +50°C

Clockwork: quartz movement battery, 168 hours rotation. Available even 24 hours rotation

Diagram disk: disk Ø 81 mm, standard scale ranges -30+30, -40+40, -10+40, -50+50

Window: 3 mm thickness glass with EPDM gasket

Writing system: synthetic fiber nib filled with easily replaceable ink, with a writing autonomy of 80 mt.

OPTIONS

On request and when ordering, it is possible to install shock-absorbing elastomers to be applied directly on the recorder flange.

The mounting of these dampers allows to diminish the nib vibrations in case of the installation on the means of transport.