

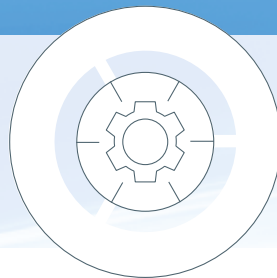

PRODUCT INFORMATION
GHM GROUP



Flow.
Paddle.



Characteristics

System

- Paddle

Evaluation

- Displays, Switching, Measuring

Nominal widths

- DN 10..200

Range

- 2..3600 l/min

Media

- Water, Oils, Gases, Aggressive media

Pressure resistance

- Max. 25 bar

Temperature

- -20..+200 °C

Approvals

- ATEX

Function and benefits

The HONSBERG paddle system for the monitoring and measurement of liquid and gaseous media is an economical alternative with a high level of operational safety for industrial plant construction.

A spring-supported paddle is positioned in the volume flow and covers a path proportional to the flow value. The contact is triggered when the selected flow value is reached.

With a change of the position of the contact, an infinitely variable adjustment of the switching point is possible.

The paddle devices are predominantly used in liquid media. The influence of viscosity is less than with unmodified piston systems.

Typical switching point change of a paddle switch with a change of viscosity.

H ₂ O	Viscosity mm ² /s				l/mm
	30	60	115	220	
4	4,0	3,8	3,5	3,0	
8	8,0	7,6	7,0	6,6	
10	10,0	9,0	8,5	8,0	
20	20,0	19,0	18,0	17,5	

Applications

- Flow switching in transformers
- Flow switching in heat exchangers
- Flow display and monitoring in hot water installations
- Testing equipment monitoring
- applications

Based on the low reduction in cross-section from the paddle in the flow area, both a good resistance to dirt particles and low pressure losses result.

The functional ratio for air and gases in relation to water is approx. 1:15, which means 1 l/min water corresponds to approximately 15 Sl/min air at 20 °C.

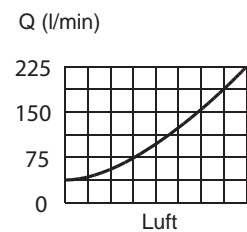
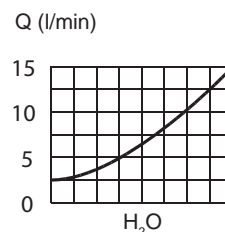

Device overview

Device	Switch	Connection	Range l/min	Pressure resistance in bar	Medium temperature	Supply voltage	Switching	Page
UR1- / UR2-...G / A	Reed switch	Female thread G 3/8..G 2 Male thread G 1/2 A	1,3..53	PN 25	-20..+110 °C (-20..+150 °C)	-	normally open or normally closed 250 V AC, 1 A, 50 VA	5
UR1 / UR2-...V	Reed switch	Soldered or welded nozzle for DN 15..80	5..179	PN 25	-20..+80 °C	-	normally open or normally closed 250 V AC, 1 A, 50 VA	7
UR1-...HM / HK	Reed switch	thread G 11/4..G 11/2 oder G2“..G3“	23..118	PN 25	-20..+110°C	-	normally open or normally closed	9
A-U1-1	ATEX switching unit I M1 Ex ia I II 1G Ex ia IIC T4 II 1D Ex iaD 20 T135				-20..+110 °C	-	normally open or normally closed	11
UR3K-...G / A	Reed switch	Female thread G 3/8..G 2	3,5..69	PN 25	-20..+110 °C	-	normally open (n.o.) 250 V AC, 1 A, 50 VA	12
UR3K-...V	Reed switch	Soldered or welded nozzle for DN 15..80	8,5..248	PN 25	-20..+110 °C	-	normally open (n.o.) 250 V AC, 1 A, 50 VA	14
UM3K-...G / A	Micro switch	Female thread G 3/8..G 2	4..93	PN 25	-20..+110 °C	-	changeover 250 V AC, 5 A	16
UM3K-...V	Micro switch	Soldered or welded nozzle for DN 15..80	10..268	PN 25	-20..+110 °C	-	changeover 250 V AC, 1 A, 50 VA	18
UI-...G / A	Proximity switch	Female thread G 3/8..G 2 Male thread G 1/2 A	1,7..55 adjusted	PN 16	-20..+60 °C	10..30 V DC	PNP / NPN	20
UB1	Micro switch	Threaded nozzle R1 “ or installation flange	20..566	PN 16	-20..+140 °C	-	changeover 250 V AC, 6 A	22
UBX	Micro switch	Oval flange or male thread R1“	Adjustment	PN 16	-40..+140 °C -50..+125 °C	-	changeover 250 V AC, 6 A	24
CRE	Micro switch	Threaded nozzle R 1 “	3,2..2760	PN 5..13	-20..+120 °C	-	changeover 250 V AC, 15 A	26
CRG	Micro switch	Threaded nozzle R 1 “	3,2..2760	PN 11	-20..+120 °C	-	changeover 250 V AC, 15 A	28

Geräteübersicht

Device	Switch	Connection	Range l/min	Pressure resistance in bar	Medium temperature	Supply voltage	Switching	Page
VM-...E	Micro switch	Installation flange	40..3600	PN 16	-20..+90 °C (-20..+200 °C)	-	changeover 250 V AC, 5 A	30
A-V2	ATEX switching head I M1 Ex ia I / II 1G Ex ia IIC T4 / II 1D Ex iaD 20 T135				20..+90 °C	-	Changeover 15..36 V, 1.5..5 A	32
A-V3	ATEX switching head II 2G Ex d IIC T6				-20..+90 °C	-	changeover 250 V AC, 5 A	33
UZ	micro switch or potentio-meter	female thread G 1/2..G 2	3..500	PN 16	-20..+100 °C	-	changeover 250 V AC, 5 A 2 x normally open 2 x nor- mally closed 250 V AC, 0,6 A, 50 VA	34
	Additional devices for UZ						potentiometer	36
TZ1-...E	micro switch or potentio-meter	installation flange	50..1050	PN 16	-20..+90 °C (-20..+200 °C)	-	change- over250 V AC, 5 A 2 x normally open 2 x normally closed 250 V AC, 0,6 A, 50 VA	37
	Additional devices for TZ1						potentiometer	39
Options	<ul style="list-style-type: none"> ○ Special connection ○ Temperature up to 250 ° ○ Plug DIN 43650-A / ISO 4400 with Diodes 							24 40 38
Accessories	<ul style="list-style-type: none"> ○ Typ ZV / ZE (Filter) ○ FL-032.... (Flange connection) ○ KB...(Round plug connector 4-pin) 							41 39 42

Errors and technical modifications reserved.

Flow Switch UR1- / UR2-...G / A



- Low pressure loss
- Compact design
- Threaded connection

Characteristics

The devices function via the principle of a spring-supported paddle, and the magnetic triggering of a reed switch.

Technical data

Switch	reed switch	
Nominal width	DN 10..50	
Process connection	brass / stainless steel - female thread G 3/8..G 1 brass / POM - male thread G 1/2 A (further process connections available on request)	
Switching range	1.3..35 l/min	for details see table "Ranges"
Q_{max.}	to 150 l/min	
Tolerance	±15 % of full scale value	
Pressure	Brass	PN 25 bar (UR1)
	Stainless steel	
	POM PPS	PN 10 bar (UR2)
Medium temperature	Brass	-20..+110 °C (optionally 150 °C) (UR1)
	Stainless steel	
	POM PPS	-20..+80 °C (UR2)
Ambient temperature	-20..+70 °C	
Media	water (oils, gases and aggressive media available on request)	
Electrical data	see "UR1 brass switching unit" or "UR1 plastic switching unit"	
Materials medium-contact	<i>Brass construction:</i> CW617N nickelled, CW614N nickelled, 1.4310, 1.4301, hard ferrite, NBR	<i>Stainless steel construction:</i> 1.4305, 1.4571, 1.4310, 1.4310, hard ferrite
	<i>Optional:</i> Body made from POM (PN 10) Body made from PPS (PN 10) Connection G 1/2 A POM (PN 10)	
Non-medium-contact materials	see "UR1 brass switching unit" or "UR1 plastic switching unit"	
Weight	see table "Dimensions and weights"	

Installation location	Standard: horizontal inwards flow; switching unit not recommended underneath; other installation positions are possible; the installation position affects the switching point and range
------------------------------	--

UR1 Brass switching unit

Wiring	normally open (n.o.) or normally closed (n.c.), no. 0.225
Switching voltage	max. 230 V AC
Switching current	max. 1 A
Switching capacity	max. 50 VA
Protection class	1 - PE connection
Ingress protection	IP 65
Electrical connection	cable 1.5 m, optionally for round plug connector M12x1, 4-pole
Materials, non-medium-contact	CW614N, nickelled, CW614N, NBR, PVC, POM

UR2 Plastic switching unit

Wiring	'Normally open', no. 0.446	Normally closed (n.c.) no. 0.447
Switching voltage	max. 230 V AC	
Switching current	max. 1 A	
Switching capacity	max. 50 VA	
Protection class	2 - safety insulation	
Ingress protection	IP 65	
Electrical connection	cable 1.5 m	
Materials, non-medium-contact	PA, PVC, POM	

pi-ho_fpa-ur1-g_d.pdf

Ranges

Details in the table correspond to horizontal inwards flow with decreasing flow rate.

UR2 (Plastic switching unit) is adjusted in the factory; please specify switching value.

G	DN	Switching range l/min H ₂ O	Types	Q _{max.} recommended
G 3/8	DN 10	2.5 - 3.5	UR.-010G.	10
G 1/2 A	DN 15	1.3 - 2.1	UR.-015A.	
G 1/2		4.0 - 4.5	UR.-015G.	20
G 3/4	DN 20	5.0 - 6.0	UR.-020G.	40
G 1	DN 25	9.5 - 11.5	UR.-025G.	60
G 1 1/4	DN 32	13.5 - 17.5	UR.-032G.	80
G 1 1/2	DN 40	30.0 - 38.0	UR.-040G.	100

Special ranges are available.

Dimensions and weights

G	Types	H	L	X	Weight kg	
					UR1	UR2
G 3/8	UR.-010GM	82	50	10	0.35	0.35
	UR.-010GK				0.40	0.40
G 1/2 A	UR.-015AM		60	12	0.35	0.30
	UR.-015AP				0.15	0.15
G 1/2	UR.-015GM	50	50	10	0.35	0.30
	UR.-015GK				0.40	0.40
G 3/4	UR.-020GM	83		12	0.35	0.35
	UR.-020GK					
G 1	UR.-025GM	87			0.40	0.40
	UR.-025GK				0.45	0.45
G 1 1/4	UR.-032GM	91			0.50	0.50
	UR.-032GK					
G 1 1/2	UR.-040GM	94			0.55	
	UR.-040GK				0.65	0.65
G 2	UR.-050GM	103			0.80	0.75
	UR.-050GK				0.95	0.95

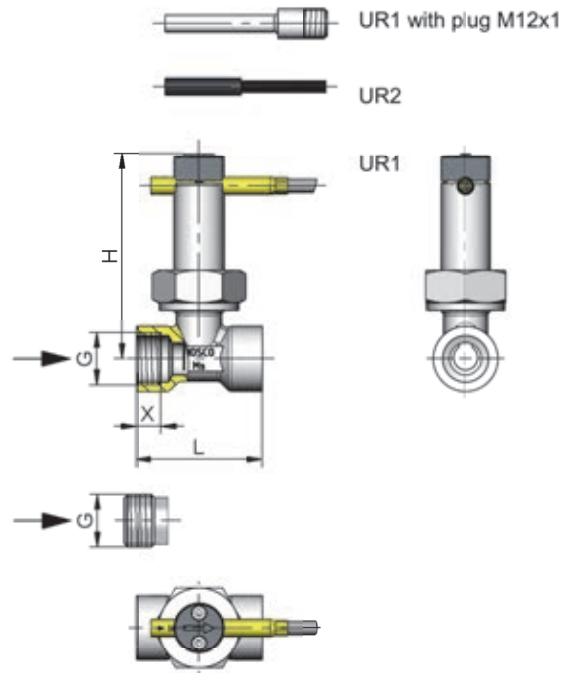

Handling and operation

Note

- Include straight calming section of 5 x DN in inlet and outlet
- Include a filter if the media are dirty (use magnetic filter for ferritic components).
- It must be ensured that the values given for voltage, current, and power are not exceeded.
- When switched on, a load must be connected in series.
- The electrical details apply to ohmic loads. Capacitive, inductive and lamp loads must be operated using a protective circuit.

Adjustment

UR1 - loosen bolts, push the switching current tube into the desired position. Retighten the bolts.
Normally closed (n.c.) or normally open (n.o.) as per table "Technical data"

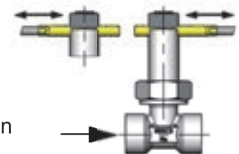

Flow Switch UR1 / UR2-...V



- Low pressure loss
- Compact design
- Soldered/welded connection

Characteristics

The devices function via the principle of a spring-supported paddle, and the magnetic triggering of a reed switch.

Technical data

Switch	reed switch	
Nominal width	DN 15..80	
Process connection	soldered/welded nozzle (further process connections available on request)	
Switching range	5..174 l/min	for details see table "Ranges"
Q_{max.}	to 600 l/min	
Tolerance	±15 % of full scale value	
Pressure	Brass	PN 25 bar (UR1)
	Stainless steel	
	PVC	PN 10 bar (UR2)
	PPS	
Medium temperature	-20..+110 °C (optionally 150 °C)	
Ambient temperature	-20..+70 °C	
Media	water (oils, gases and aggressive media available on request)	
For electrical data see "UR1 Brass switching unit" or "UR1 Plastic switching unit"	see "UR1 Brass switching unit" or "UR1 Plastic switching unit"	
Materials medium-contact	<i>Brass construction:</i>	<i>Stainless steel construction:</i>
	CW617N nickelled, CW614N, 1.4310, 1.4301, hard ferrite, NBR	1.4305, 1.4571, 1.4310, 1.4310, hard ferrite PTFE-coated, FKM
	<i>Optional:</i> Body made from POM (PN 10) Body made from PPS (PN 10)	

Non-medium-contact materials	see "UR1 Brass switching unit" or "UR1 Plastic switching unit"
Weight	see table "Dimensions and weights"
Installation location	Standard: horizontal inwards flow; switching unit not recommended underneath; other installation positions are possible; the installation position affects the switching point and range.

UR1 Brass switching unit

Wiring	normally open (n.o.) or normally closed (n.c.), no. 0.225
Switching voltage	max. 230 V AC
Switching current	max. 1 A
Switching cap.	max. 50 VA
Protection class	1 - PE connection
Ingress protection	IP 65
Electrical connection	cable 1.5 m, optionally for round plug connector M12x1, 4-pole
Materials, non-medium-contact	CW614N, nickelled, CW614N, NBR, PVC, POM

UR2 Plastic switching unit

Wiring	Normally open (n.o.) 0.446 Normally closed (n.c.) 0.447
Switching voltage	max. 230 V AC
Switching current	max. 1 A
Switching cap.	max. 50 VA
Protection class	2 - Safety insulation
Ingress protection	IP 65
Electrical connection	cable 1.5 m
Materials, non-medium-contact	PA, PVC, POM

Ranges

Details in the table correspond to horizontal inwards flow with decreasing flow rate. UR2 (Plastic switching unit) is adjusted in the factory; please specify switching value.

DN	Switching range l/min H ₂ O	Types	Q _{max.} recommended
DN 15	5.0 - 6.5	UR.-015V.	20
DN 20	10.0 - 15.5		40
DN 25	11.0 - 13.0	UR.-025V.	80
DN 32	26.0 - 33.0		100
DN 40	37.0 - 42.5		150
DN 50	47.5 - 60.0	UR.-050V.	200
DN 65	95.0 - 117.0		400
DN 80	147.0 - 179.0		600

Special ranges are available.

Dimensions and weights

DN	Types	H	D	A	B	Weight kg	
						UR1	UR2
DN 15..20	UR.-015V.	18.0	13	-	-	0.25	0.20
DN 25..50	UR.-025V.	27.5	-	12	16		
DN 50..80	UR.-050V.	42.0			19		

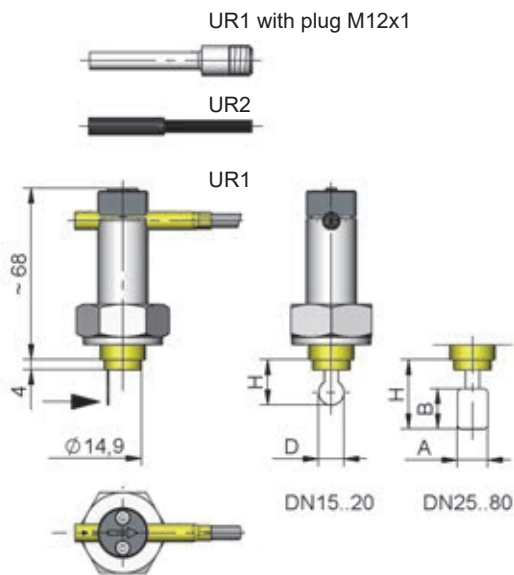

Handling and operation

Note

- Include straight calming section of 5 x DN in inlet and outlet
- If the media are dirty, install a filter (use magnetic filter for ferritic components).
- It must be ensured that the values given for voltage, current, and power are not exceeded.
- When switched on, a load must be connected in series.
- The electrical details apply to ohmic loads. Capacitive, inductive and lamp loads must be operated using a protective circuit.

Adjustment

UR1 - loosen bolts, push the switching current tube into the desired position. Retighten the bolts.
Normally closed (n.c.) or normally open (n.o.) as per table "Technical data"

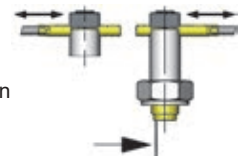

Ordering code

1. 2. 3. 4. 5.
UR - V

○=Option

1. Switching unit	
1	brass
2	○ plastic (already adjusted, specify switching value and normally closed (n.c.) or normally open (n.o.))
2. Nominal width	
015	DN 15..25
025	DN 25..40
050	DN 50..80
3. Process connection	
V	soldered/welded nozzle
4. Connection material	
M	brass
K	stainless steel
5. Switching unit options	
A	for switching unit ATEX A-U1.1 The switching head is ordered in addition.
S	○ for round plug connector M12x1, 4-pole

Options

- Switching ranges for oil or gas
- Special quantity
- Adhesive PVC fitting

Ordering information

- Specify direction of flow, medium, and switching range, UR1 or switching value UR2.
- For UR2 specify normally closed (n.c.) or normally open (n.o.).
- For oils, state viscosity, temperature and designation (e.g. ISO VG 68) (enquire about range).
- For gases, state pressure (relative or absolute), temperature and medium (e.g. air) (enquire about range).

Flow switch UR1-...HM / HK

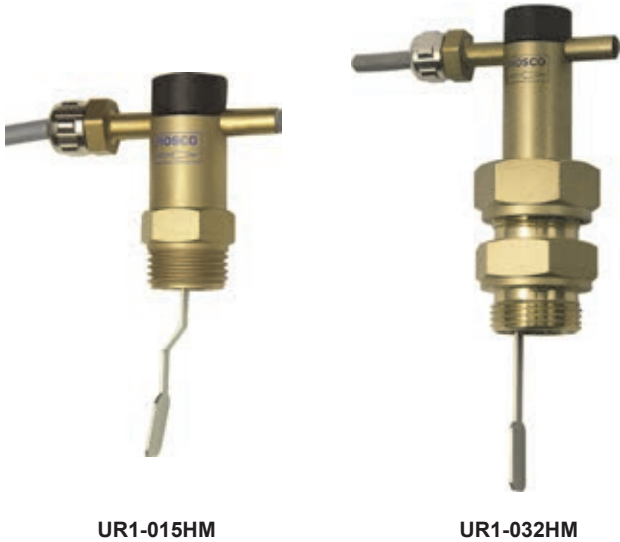

- Highly reproducible
- Low pressure loss
- Hermetic separation between electrical and hydraulic component
- Stress-fixing of the switching unit by means of plastic head

Characteristics

The devices function via the principle of a spring-supported paddle, and the magnetic triggering of a reed switch.

Technical data

Switch	Reed switch	
Nominal width	DN 32..80	
Process connection	brass / stainless steel - Screw-in thread G 1 1/4..G 1 1/2 or G2" ..G3"	
Switching range	23..118 l/min	For details see table "Ranges"
Q_{max.}	up to 600 l/min	
Hysteresis	Depending on the switching value, minimum ±0.7 l/min	
Tolerance	±15 % of full scale value	
Pressure resistance	PN 25 bar	
Medium temperature	-20..+110 °C	
Ambient temperature	-20..+70 °C	
Media	Water, oils (gases and aggressive media available on request)	

Wiring	Wiring 0.225 normally opened or 'normally closed'	
Switching voltage	230 V AC	
Switching current	1 A	
Switch performance	50 VA	
Cable length	1.5 m	
Ingress protection	IP 65	
Protection class	(1PE connection)	
Materials medium-contact	<i>Brass construction:</i> CW614N , 1.4301, 1.4571, 1.4310, Hard ferrite, NBR	<i>Stainless steel construction:</i> 1.4305, 1.4571, 1.4301, 1.4310, Hard ferrite, Viton
Non-medium-contact materials	POM	
Weight	UR1-015HM / HK: 0.18 kg UR1-032HM / HK: 0.38 kg	
Installation location	Standard: horizontal inwards flow; switching unit not recommended underneath; other installation positions are possible; the installation position affects the switching point and range.	

Ranges

The adjustment range is suitable for horizontally decreasing flows. Measured in DIN 2448 tube with normal wall thickness.

Types	DN	Adjustment range l/min H ₂ O	Q _{max.} recommended
UR1-015HM	DN 32	23 - 30	100
	DN 40	33 - 44	150
UR1-032HM	DN 50	38 - 48	200
	DN 65	60 - 84	400
	DN 80	81 - 118	600
UR1-015HK	DN 32	23 - 30	100
	DN 40	33 - 44	150
UR1-032HK	DN 50	38 - 48	200
	DN 65	60 - 84	400
	DN 80	81 - 118	600

Dimensions

UR1-015H.

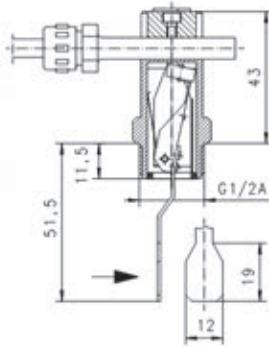

UR1-032H.

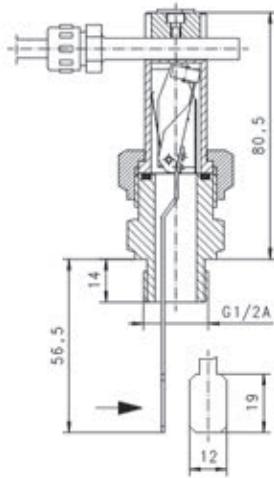

Handling and operation

Note

- Include straight calming section of 5 x DN in inlet and outlet
- Include a filter if the media are dirty (use magnetic filter for ferritic components).
- It must be ensured that the values given for voltage, current, and power are not exceeded.
- When switched on, a load must be connected in series.
- The electrical details apply to ohmic loads. Capacitive, inductive and lamp loads must be operated using a protective circuit.

Adjustment

UR1 - loosen bolts, push the switching current tube into the desired position. Retighten the bolts.
Normally closed or normally open
Normally closed

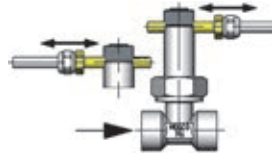

Ordering code

1. 2. 3. 4.

UR1-

○=Option

1. Nominal widths	
015	DN 32..40
032	DN 50..80
2. Process connection	
H	Screw-in thread
3. Connection material	
M	Brass
K	stainless steel
4. Switching unit options	
A	○ For switching unit ATEX A-U1.1 The switching head is ordered in addition.

Options

- Switching ranges for oil or gas
- Soldered copper fitting
- Special values
- Adhesive PVC fitting

Ordering information

- Specify direction of flow, medium, and switching range.
- For oils, state viscosity, temperature and designation (e.g. ISO VG 68) (enquire about range).
- For gases, state pressure (relative or absolute), temperature and medium (e.g. air) (enquire about range).

Switching Head A-U1-1

For device UR1



- I M1 Ex ia I Ma
- II 1G Ex ia IIC T4 Ga
- II 1D Ex IIIC T135°C Da

Characteristics

Intrinsically safe switching unit with reed switch and ATEX approval, for the UR1 range of devices, for use in intrinsically safe power circuits.

Technical data

Switch	reed switch
Medium temperature	-20..+110 °C
Ambient temperature	-20..+50 °C
Weight	0.05 kg additionally
Wiring	normally open (n.o.) or normally closed (n.c.), no. 0.442
Switching voltage	max. 30 V
Switching current	max. 1 A
Switching capacity	max. 50 W
Protection class	3
Ingress protection	IP 65
Electrical connection	cable 2.5 m, other cable lengths up to max. 5 m are optionally available

Dimensions

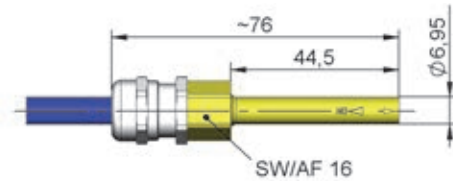

Handling and operation

Note

- For use only in intrinsically safe power circuits - Provide a suitable isolating amplifier.
- Cable lengths max. 5 m.
- It must be ensured that the values given for voltage, current, and power are not exceeded.
- When switched on, a load must be connected in series.
- The electrical details apply to ohmic loads. Capacitive, inductive and lamp loads must be operated using a protective circuit.

Adjustment

Loosen bolt(s), push the switching current tube into the desired position. Retighten the bolt(s). Normally closed (n.c.) or normally opened (n.o.) as per table "Technical data"

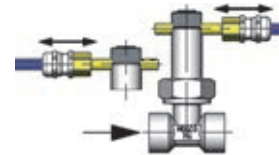

Ordering code

The base device is ordered, e.g. UR1-015GMA with switching head A-U1-1.

A-U1 - ^{1.} 1

1.	Device series
1	for UR1

Flow Switch UR3K-...G / A



- Threaded connection
- Reed switch
- Low pressure loss
- Compact design
- Threaded connection
- Plug DIN 43650-A / ISO 4400

Characteristics

The devices function via the principle of a spring-supported paddle, and the magnetic triggering of a reed switch.

Technical data

Switch	reed switch	
Nominal width	DN 10..50	
Process connection	female thread G 3/8..G 1 (further process connections available on request)	
Switching range	3.5..69 l/min	for details see table "Ranges"
Q_{max.}	to 150 l/min	
Tolerance	±15 % of full scale value	
Pressure resistance	PN 25 bar	
Medium temperature	-20..+110 °C	
Ambient temperature	-20..+70 °C	
Media	water (oils, gases and aggressive media available on request)	
Wiring	normally open (n.o.) No. 0.372	
Switching voltage	max. 230 V AC	
Switching current	max. 1 A	
Switching capacity	max. 50 VA	
Protection class	2 - safety insulation	
Ingress protection	IP 65	
Electrical connection	plug DIN 43650-A / ISO 4400, optionally for round plug connector M12x1, 4-pole	
Materials medium-contact	<i>Brass construction:</i> CW617N nickelled, CW614N nickelled, 1.4310, 1.4301, hard ferrite, NBR	<i>Stainless steel construction:</i> 1.4305, 1.4571, 1.4310, 1.4310, Hard ferrite PTFE coated, FKM

Non-medium contact materials	ABS, PA, NBR
Weight	see table "Dimensions and weights"
Installation location	Standard: horizontal inwards flow; switching head not recommended underneath; other installation positions are possible; the installation position affects the switching point and range.

Ranges

Details in the table correspond to horizontal inwards flow with decreasing flow rate.

G	DN	Switching range l/min H ₂ O	Types	Q _{max.} recommended
G 3/8	DN 10	3.5 - 5.0	UR3K-010G.050	10
G 1/2	DN 15	5.0 - 6.5	UR3K-015G.065	20
G 3/4	DN 20	6.0 - 8.5	UR3K-020G.085	40
G 1	DN 25	12.0 - 15.0	UR3K-025G.150	60
G 1 1/4	DN 32	20.0 - 27.0	UR3K-032G.270	80
G 1 1/2	DN 40	34.0 - 44.0	UR3K-040G.440	100
G 2	DN 50	54.0 - 69.0	UR3K-050G.690	150

Special ranges are available.

Dimensions and weights

G	Types	H	L	X	Weight kg
G 3/8	UR3K-010GM	87	50	10	0.45
	UR3K-010GK				0.50
G 1/2	UR3K-015GM	88	50	10	0.40
	UR3K-015GK				0.45
G 3/4	UR3K-020GM	92	50	12	0.50
	UR3K-020GK				
G 1	UR3K-025GM	96	50	12	0.60
	UR3K-025GK				
G 1 1/4	UR3K-032GM	99	50	12	0.75
	UR3K-032GK				
G 1 1/2	UR3K-040GM	108	50	12	0.85
	UR3K-040GK				
G 2	UR3K-050GM	108	50	12	1.05
	UR3K-050GK				

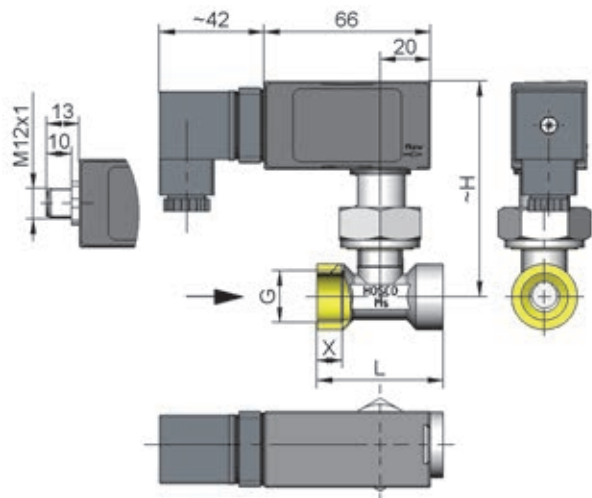

Handling and operation

Note

- Include straight calming section of 5 x DN in inlet and outlet
- When tightening the union nut, the connection piece must be counteracted using an open-ended spanner (SW 19).
- If the media are dirty, install a filter (use magnetic filter for ferritic components).
- It must be ensured that the values given for voltage, current, and power are not exceeded.
- When switched on, a load must be connected in series.
- The electrical details apply to ohmic loads. Capacitive, inductive and lamp loads must be operated using a protective circuit.

Adjustment

To adjust, open the slider. Adjustment is made using the adjustment screw with a lengthways slot; this is located under the valve.

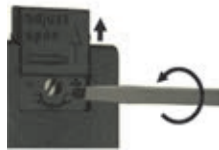

Turn clockwise for a lower switching point; turn anticlockwise for a higher switching point. After adjustment, close the slider again.

Example: The adjustment range 20 to 27 l/min corresponds to 7 l/min Adjustment option in 7 revolutions. Adjustment is therefore 1 l/min for each revolution.

Ordering code

UR3K - 1. 2. 3. 4.
UR3K - **G**

1. Nominal width	
010	DN 10 - G 3/8
015	DN 15 - G 1/2
020	DN 20 - G 3/4
025	DN 25 - G 1
032	DN 32 - G 1 1/4
040	DN 40 - G 1 1/2
050	DN 50 - G 2
2. Process connection	
G	female thread
3. Connection material	
M	brass
K	stainless steel
4. Switching range H ₂ O for horizontal inwards flow	
050	3.5 - 5.0 l/min
065	5.0 - 6.5 l/min
085	6.0 - 8.5 l/min
150	12.0 - 15.0 l/min
270	20.0 - 27.0 l/min
440	34.0 - 44.0 l/min
690	54.0 - 69.0 l/min

Options

- Connection for round plug-in connector
- Signal lamp red or red/green in the plug DIN 43650-A
- Protective bellows
- Switching ranges for oil or gas
- Special values
- Soldered copper fitting
- Adhesive PVC fitting
- Male thread G 1/2 A - brass

Ordering information

- Specify direction of flow, medium, and switching range.
- For oils, state viscosity, temperature and designation (e.g. ISO VG 68) (enquire about range).
- For gases, state pressure (relative or absolute), temperature and medium (e.g. air) (enquire about range).

Flow Switch UR3K-...V



- Soldered/welded connection
- Reed switch
- Low pressure loss
- Compact design
- Threaded connection
- Plug DIN 43650-A / ISO 4400

Characteristics

The devices function via the principle of a spring-supported paddle, and the magnetic triggering of a reed switch.

Technical data

Switch	reed switch	
Nominal width	DN 15..80	
Process connection	soldered/welded nozzle (further process connections available on request)	
Switching range	8.5..248 l/min	for details see table "Ranges"
Q_{max.}	to 600 l/min	
Tolerance	±15 % of full scale value	
Pressure resistance	PN 25 bar	
Medium temperature	-20..+110 °C	
Ambient temperature	-20..+70 °C	
Media	water (oils, gases and aggressive media available on request)	
Wiring	normally open (n.o.) No. 0.372	
Switching voltage	max. 230 V AC	
Switching current	max. 1 A	
Switching capacity	max. 50 VA	
Protection class	2 - safety insulation	
Ingress protection	IP 65	
Electrical connection	plug DIN 43650-A / ISO 4400, optionally for round plug connector M12x1, 4-pole	

Materials medium-contact	<i>Brass construction:</i> CW614N, CW614N nickelled, 1.4310, 1.4301, hard ferrite, NBR	<i>Stainless steel construction:</i> 1.4305, 1.4571, 1.4310, NBR, hard ferrite PTFE coated, FKM
Non-medium contact materials	ABS, PA, NBR	
Weight	0.3 kg	
Installation location	Standard: horizontal inwards flow; switching head not recommended underneath; other installation positions are possible; the installation position affects the switching point and range.	

Ranges

Details in the table correspond to horizontal inwards flow with decreasing flow rate.

DN	Switching range l/min H ₂ O	Types	Q _{max.} recommended
DN 15	8.5 - 11.0	UR3K-015V.	20
DN 20	14.0 - 19.0		40
DN 25	15.0 - 20.0	UR3K-025V.	80
DN 32	39.0 - 52.0		100
DN 40	49.0 - 64.0		150
DN 50	68.0 - 84.0	UR3K-050V.	200
DN 65	127.0 - 163.0		400
DN 80	189.0 - 248.0		600

Special ranges are available.

Dimensions

DN	Types	H	D	A	B
DN 15..20	UR3K-015V.	18.5	13	-	-
DN 25..40	UR3K-025V.	27.0	-	12	16
DN 50..80	UR3K-050V.	40.5	-	-	19

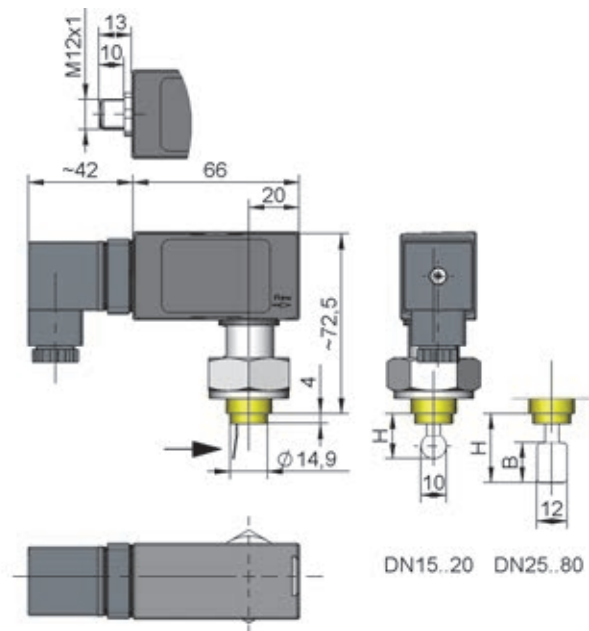

Handling and Operation

Note

- Include straight calming section of 5 x DN in inlet and outlet
- When tightening the union nut, the connection piece must be countered using an open-ended spanner (SW 19).
- Include a filter if the media are dirty (use magnetic filter for ferritic components).
- It must be ensured that the values given for voltage, current, and power are not exceeded.
- When switched on, a load must be connected in series.
- The electrical details apply to ohmic loads. Capacitive, inductive and lamp loads must be operated using a protective circuit.

Adjustment

To adjust, open the slider. Adjustment is made using the adjustment screw with a lengthways slot; this is located under the valve.

Turn clockwise for a lower switching point; turn anticlockwise for a higher switching point. After adjustment, close the slider again.



Example: The adjustment range 20 to 27 l/min corresponds to 7 l/min Adjustment option in 7 revolutions. Adjustment is therefore 1 l/min for each revolution.

Ordering code

UR3K - 1. 2. 3.
UR3K - V

○=Option

1. Nominal width	
015	DN 15..20
025	DN 25..40
050	DN 50..80
2. Process connection	
V	soldered/welded nozzle
3. Connection material	
M	brass
K	stainless steel

Options

- Connection for round plug-in connector
- Signal lamp red or red/green in the plug DIN 43650-A
- Protective bellows
- Switching ranges for oil or gas
- Special quantity
- Adhesive PVC fitting

Ordering information

- Specify direction of flow, medium, and switching range.
- For UR2 specify normally closed (n.c.) or normally open (n.o.).
- For oils, state viscosity, temperature and designation (e.g. ISO VG 68) (enquire about range).
- For gases, state pressure (relative or absolute), temperature and medium (e.g. air) (enquire about range).

Flow Switch UM3K-...G / A



- Threaded connection
- Micro switch
- Low pressure loss
- Compact design
- Threaded connection
- Plug DIN 43650-A / ISO 4400

Characteristics

The devices function via the principle of a spring-supported paddle, and the magnetic triggering of a micro switch.

Technical data

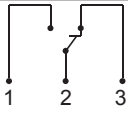
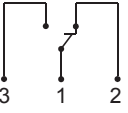
Switch/sensor	micro switch	
Nominal width	DN 10..50	
Process connection	female thread G 3/8..G 1 (further process connections available on request)	
Switching range	4..93 l/min	for details see table "Ranges"
Q_{max.}	to 150 l/min	
Tolerance	±15 % of full scale value	
Pressure resistance	PN 25 bar	
Medium temperature	-20..+110 °C	
Ambient temperature	-20..+70 °C	
Media	water (oils, gases and aggressive media available on request)	
Wiring	changeover no. 0.371  optionally changeover no. 0.282  optionally red or red / green diode in the DIN 43650-A plug	
Switching voltage	max. 250 V AC	
Switching current	max. 5 A (round plug connector max. 4 A)	
Protection class	2 - safety insulation	
Ingress protection	IP 65	
Electrical connection	plug DIN 43650-A / ISO 4400, optionally for round plug connector M12x1, 4-pole	

Materials medium-contact	<i>Brass construction:</i> CW617N nickelled, CW614N nickelled, 1.4310, 1.4301, hard ferrite, NBR	<i>Stainless steel construction:</i> 1.4305, 1.4571, 1.4301, 1.4310, hard ferrite PTFE-coated, FKM
Non-medium contact materials	ABS, PA, NBR	
Weight	see table "Dimensions and weights"	
Installation location	Standard: horizontal inwards flow; switching head not recommended underneath; other installation positions are possible; the installation position affects the switching point and range.	

Ranges

Details in the table correspond to horizontal inwards flow with decreasing flow rate

G	DN	Switching range l/min H ₂ O	Types	Q _{max.} recommended
G 3/8	DN 10	4.0 - 5.5	UM3K-010G.055	10
G 1/2	DN 15	5.5 - 7.0	UM3K-015G.070	20
G 3/4	DN 20	7.5 - 10.0	UM3K-020G.100	40
G 1	DN 25	14.0 - 18.0	UM3K-025G.180	60
G 1 1/4	DN 32	22.0 - 30.0	UM3K-032G.300	80
G 1 1/2	DN 40	37.0 - 50.0	UM3K-040G.500	100
G 2	DN 50	67.0 - 93.0	UM3K-050G.930	150

Special ranges are available.

Dimensions and weights

G	Types	H	L	X	Weight kg
G 3/8	UM3K-010GM	87	50	10	0.45
	UM3K-010GK				0.50
G 1/2	UM3K-015GM	88	50	10	0.40
	UM3K-015GK				0.45
G 3/4	UM3K-020GM	92	50	12	0.50
	UM3K-020GK				
G 1	UM3K-025GM	96	50	12	0.60
	UM3K-025GK				
G 1 1/4	UM3K-032GM	99	50	12	0.75
	UM3K-032GK				
G 1 1/2	UM3K-040GM	108	50	12	0.85
	UM3K-040GK				
G 2	UM3K-050GM	108	50	12	1.05
	UM3K-050GK				

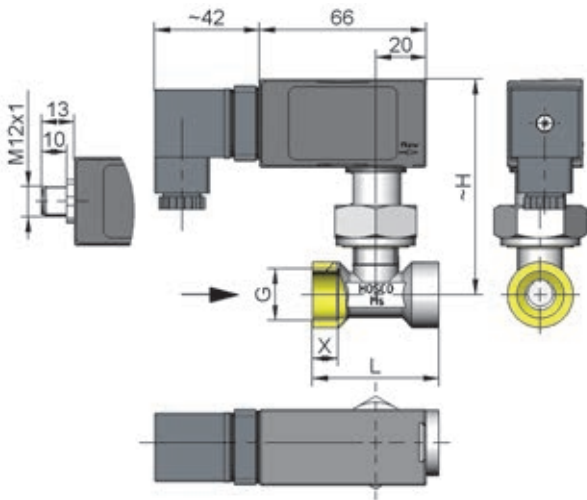

Handling and operation

Note

- Include straight calming section of 5 x DN in inlet and outlet
- When tightening the union nut, the connection piece must be countered using an open-ended spanner (SW 19).
- If the media are dirty, install a filter (use magnetic filter for ferritic components).
- It must be ensured that the values given for voltage, current, and power are not exceeded.
- When switched on, a load must be connected in series.
- The electrical details apply to ohmic loads. Capacitive and inductive loads must be operated using a protective circuit.

Adjustment

To adjust, open the slider. Adjustment is made using the adjustment screw with a lengthways slot; this is located under the valve.

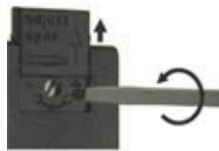

Turn clockwise for a lower switching point; turn anticlockwise for a higher switching point. After adjustment, close the slider again.

Example: The adjustment range 20 to 27 l/min corresponds to 7 l/min Adjustment option in 7 revolutions. Adjustment is therefore 1 l/min for each revolution.

Ordering code

UM3K - 1. 2. 3. 4.
 UM3K - **G**

1. Nominal width	
010	DN 10 - G 3/8
015	DN 15 - G 1/2
020	DN 20 - G 3/4
025	DN 25 - G 1
032	DN 32 - G 1 1/4
040	DN 40 - G 1 1/2
050	DN 50 - G 2
2. Process connection	
G	female thread
3. Connection material	
M	brass
K	stainless steel
4. Switching range H ₂ O for horizontal inwards flow	
055	4.0 - 5.5 l/min
070	5.5 - 7.0 l/min
100	7.5 - 10.0 l/min
180	14.0 - 18.0 l/min
300	22.0 - 30.0 l/min
500	37.0 - 50.0 l/min
930	67.0 - 93.0 l/min

Options

- Connection for round plug-in connector
- Signal lamp red or red/green in the plug DIN 43650-A
- Gold contact 125 V AC / 30 V DC, 100 mA
- Protective bellows
- Switching ranges for oil or gas
- Special values
- Soldered copper fitting
- Adhesive PVC fitting
- Male thread G 1/2 A - brass

Ordering information

- Specify direction of flow, medium, and switching range.
- For oils, state viscosity, temperature and designation (e.g. ISO VG 68) (enquire about range).
- For gases, state pressure (relative or absolute), temperature and medium (e.g. air) (enquire about range).

Flow Switch UM3K-...V



- Soldered/welded connection
- Micro switch
- Low pressure loss
- Compact design
- Threaded connection
- Plug DIN 43650-A / ISO 4400

Characteristics

The devices function via the principle of a spring-supported paddle, and the magnetic triggering of a micro switch.

Technical data

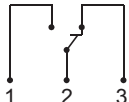
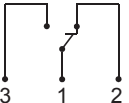
Switch	micro switch	
Nominal width	DN 15..80	
Process connection	soldered/welded nozzle (further process connections available on request)	
Switching range	10..268 l/min	for details see table "Ranges"
Q_{max.}	to 600 l/min	
Tolerance	±15 % of full scale value	
Pressure	PN 25 bar	
Medium temperature	-20..+110 °C	
Ambient temperature	-20..+70 °C	
Media	water (oils, gases and aggressive media available on request)	
Wiring	changeover no. 0.371  optionally changeover No. 0.282  optionally red or red / green diode in the DIN 43650-A plug	
Switching voltage	max. 250 V AC (gold contact max. 125 V AC / 30 V DC)	
Switching current	max. 5 A (round plug connector max. 4A) (gold contact max. 100 mA)	
Protection class	2 - safety insulation	
Ingress protection	IP 65	
Electrical connection	plug DIN 43650-A / ISO 4400, optionally for round plug connector M12x1, 4-pole	

Materials medium-contact	<i>Brass construction:</i> CW617N, CW614N nickelled, 1.4310, 1.4301, hard ferrite, NBR	<i>Stainless steel construction:</i> 1.4305, 1.4571, 1.4310, 1.4310, Hard ferrite PTFE coated, FKM
Non-medium-contact materials	ABS, PA, NBR	
Weight	0.3 kg	
Installation location	Standard: horizontal inwards flow; switching head not recommended underneath; other installation positions are possible; the installation position affects the switching point and range.	

Ranges

Details in the table correspond to horizontal inwards flow with decreasing flow rate

DN	Switching range l/min H ₂ O	Types	Q _{max.} recommended
DN 15	10.0 - 13.0	UM3K-015V.	20
DN 20	17.5 - 22.0		20
DN 25	18.0 - 22.5	UM3K-025V.	40
DN 32	44.0 - 55.5		40
DN 40	55.5 - 72.0	UM3K-050V.	40
DN 50	75.0 - 90.0		80
DN 65	151.0 - 186.0		80
DN 80	228.0 - 238.0		80

Special ranges are available.

Dimensions

DN	Types	H	D	A	B
DN 15..20	UM3K-015V.	18.5	13	-	-
DN 25..40	UM3K-025V.	27.0	-	12	16
DN 50..80	UM3K-050V.	40.5	-	-	19

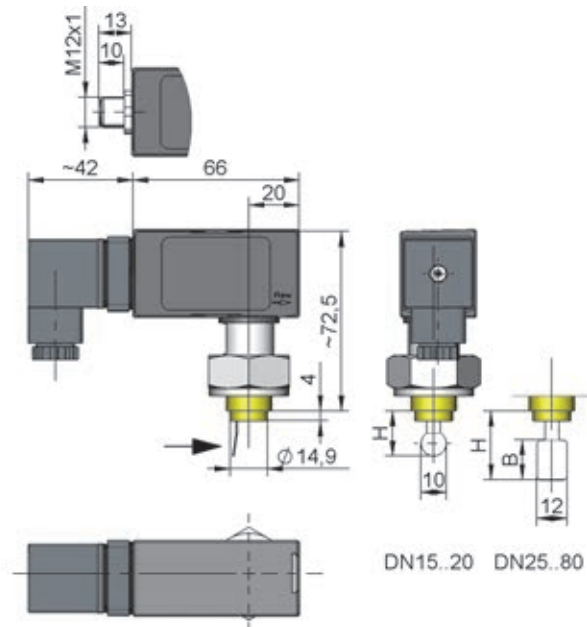

Handling and Operation

Note

- Include straight calming section of 5 x DN in inlet and outlet
- When tightening the union nut, the connection piece must be countered using an open-ended spanner (SW 19).
- If the media are dirty, install a filter (use magnetic filter for ferritic components).
- It must be ensured that the values given for voltage, current, and power are not exceeded.
- When switched on, a load must be connected in series.
- The electrical details apply to ohmic loads. Capacitive and inductive loads must be operated using a protective circuit.

Adjustment

To adjust, open the slider. Adjustment is made using the adjustment screw with a lengthways slot; this is located under the valve.

Turn clockwise for a lower switching point; turn anticlockwise for a higher switching point.

After adjustment, close the slider again.

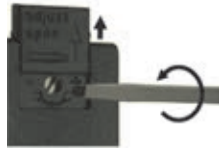

Example: The adjustment range 20 to 27 l/min corresponds to 7 l/min Adjustment option in 7 revolutions. Adjustment is therefore 1 l/min for each revolution.

Ordering code

UM3K - 1. 2. 3.
 V

○=Option

1. Nominal width	
015	DN 15..20
025	DN 25..40
050	DN 50..80
2. Process connection	
V	soldered/welded nozzle
3. Connection material	
M	brass
K	stainless steel

Options

- Connection for round plug-in connector
- Signal lamp red or red/green in the plug DIN 43650-A
- Gold contact 125 V AC / 30 V DC, 100 mA
- Protective bellows
- Switching ranges for oil or gas
- Special values
- Adhesive PVC fitting

Ordering information

- Specify direction of flow, medium, and switching range.
- For oils, state viscosity, temperature and designation (e.g. ISO VG 68) (enquire about range).
- For gases, state pressure (relative or absolute), temperature and medium (e.g. air) (enquire about range).

Flow Switch UI-...G / A



- For media with ferritic components
- Low pressure loss
- Compact design
- Inductive proximity switch

Characteristics

The devices function via the principle of a spring-supported paddle, and the triggering of an inductive proximity switch.

Technical data

Switch	inductive proximity switch	
Nominal width	DN 10..50	
Process connection	brass / stainless steel - female thread G 3/8..G 1 brass / POM - male thread G 1/2 A (further process connections available on request)	
Adjustment range	1.7..55 l/min	for details see table "Ranges"
Q_{max.}	to 150 l/min	
Tolerance	±5 % of full scale value	
Pressure resistance	PN 16 bar	
Medium temperature	-20..+60 °C	
Ambient temperature	-20..+60 °C	
Media	water (oils and gases available on request)	
Wiring	no. 0.319 (Z=Load) PNP optionally NPN 	
Supply voltage	10..30 V DC	
Current consumption	< 10 mA	

Current under load	max. 100 mA
Voltage drop	< 3 V
Ingress protection	IP 67
Electrical connection	Cable 2 m
Materials medium-contact	POM GV, 1.4310, 1.4301, NBR Connection: CW614N nickelled or POM
Non-medium-contact materials	POM, CW614N nickelled, PVC
Weight	see table "Dimensions and weights"
Installation location	Standard: horizontal inwards flow; switching unit not recommended underneath; other installation positions are possible; the installation position affects the switching point and range.

Ranges

Details in the table correspond to horizontal inwards flow with decreasing flow rate.

G	DN	Switching value l/min H ₂ O Choose between	Types	Q _{max.} recommended
G 3/8	DN 10	2.0 - 4.0	UI-010G040	10
G 1/2 A	DN 15	1.7 - 2.5	UI-015A025	
G 1/2		4.0 - 6.0	UI-015G060	20
G 3/4	DN 20	6.0 - 8.0	UI-020G080	40
G 1	DN 25	10.0 - 17.0	UI-025G170	60
G 1 1/4	DN 32	18.0 - 27.0	UI-032G270	80
G 1 1/2	DN 40	28.0 - 37.0	UI-040G370	100
G 2	DN 50	45.0 - 55.0	UI-050G550	150

Special ranges are available.

Dimensions and weights

G	Types	H	L	X	Weight kg
G 3/8	UI.-010GM	69	50	10	0.40
G 1/2 A	UI.-015AM		60	12	
		UI.-015AP			0.15
G 1/2	UI.-015GM	71	50	10	0.40
G 3/4	UI.-020GM			12	
G 1	UI.-025GM	74			0.45
G 1 1/4	UI.-032GM	79			0.50
G 1 1/2	UI.-040GM	82			0.60
G 2	UI.-050GM	91			0.80

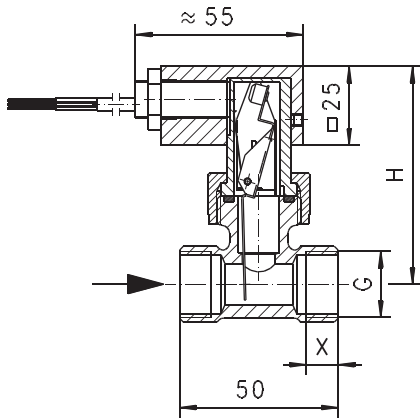

Handling and operation

- Include straight calming section of 5 x DN in inlet and outlet
- If the media are dirty, install a filter.

Ordering code

UI - 1. - 2. - 3. - 4. - 5.

○=Option

1. Nominal width									
010	DN 10 - G 3/8								
015	DN 15 - G 1/2								
	DN 15 - G 1/2 A								
020	DN 20 - G 3/4								
025	DN 25 - G 1								
032	DN 32 - G 1 1/4								
040	DN 40 - G 1 1/2								
050	DN 50 - G 2								
2. Process connection									
G	female thread							●	●
A	male thread							●	
3. Connection material									
M	brass	●	●	●	●	●	●	●	●
K	stainless steel	●	●	●	●	●	●	●	●
P	POM (PN 10)							●	
4. Switching range H ₂ O for horizontal inwards flow									
025	1.7 - 2.5 l/min							●	
040	2.0 - 4.0 l/min								●
060	4.0 - 6.0 l/min								●
080	6.0 - 8.0 l/min							●	
170	10.0 - 17.0 l/min							●	
270	18.0 - 27.0 l/min							●	
370	28.0 - 37.0 l/min							●	
550	45.0 - 55.0 l/min							●	
5. Output signal									
P	PNP								
N	○ NPN								

Options

- Switching ranges for oil or gas
- Special quantity

Ordering information

- Specify direction of flow, medium, and switching range.
- For oils, state viscosity, temperature and designation (e.g. ISO VG 68) (enquire about range).
- For gases, specify pressure (relative or absolute), temperature and medium (e.g. air) (enquire about range).

Flow Switch UB1



- Can be used from nominal width DN 25..200
- Micro switch with gold-plating for small currents, and silver-plating for larger currents
- Visual function control through transparent cover
- Suitable for media with ferritic particles.

Characteristics

The devices function via the principle of a paddle supported by a metal bellows, and the triggering of a microswitch.

Technical data

Switch	Micro switch			
Nominal width	DN 25..200			
Process connection	male thread R 1" or installation flange DIN 2527 DN 32 PN 16 sealing surface as per DIN 2526 form C			
Switching range	1.2..34 m ³ /h	for details see table "Ranges"		
Q_{max.}	up to 75 m ³ /h			
Tolerance	±15 % of full scale value			
Pressure resistance	PN 16 bar			
Medium temperature	-20..+140 °C (no superheated steam)			
Ambient temperature	-20..+70 °C			
Media	water (oils and aggressive media available on request)			
Wiring	changeover no. 0.371			
Switching voltage/ Switching current	max.	250 V AC/DC	A max. ohmic	A max. inductive
		125 V AC/DC	6 A	1.5 A
		24 V DC	6 A	2 A
		12 V DC	6 A	5 A
	min.	4 V	A min.	
			1 mA	
Protection class	2 - safety insulation			
Ingress protection	IP 65			

Electrical connection	plug DIN 43650-A / ISO 4400, optionally for round plug connector M12x1, 4-pole (max. 4A)	
Materials medium-contact	<i>Brass construction:</i> CW614N nickelled, 1.4305, 1.4310, 1.4541, FVMQ	<i>Stainless steel construction:</i> 1.4305, 1.4310, 1.4541, FKM
Non-medium-contact materials	PC, PA	
Weight	Threaded type:	1.3 kg
	Flanged type:	2.5 kg
Installation location	Standard: horizontal inwards flow; switching unit not recommended underneath; other installation positions are possible; the installation position affects the switching point and range.	

Ranges

Details in the table correspond to horizontal inwards flow with decreasing flow rate.

DN 25..32 threaded type only. DN 125..200 available on request

DN	Switching range m ³ /h H ₂ O			Q _{max. recom- mended}
	Paddle 1	Paddle 1,2	Paddle 1,2,3	
25	2.0 - 2.5			4
32	3.0 - 3.5			8
40	4.0 - 5.0			12
50	8.8 - 10.2	3.5 - 4.3		20
65	16.5 - 20.0	9.2 - 11.0		30
80	25.5 - 31.0	14.0 - 18.0	8.7 - 11.0	45
100	44.0 - 55.0	27.0 - 32.0	17.0 - 22.0	75

Dimensions

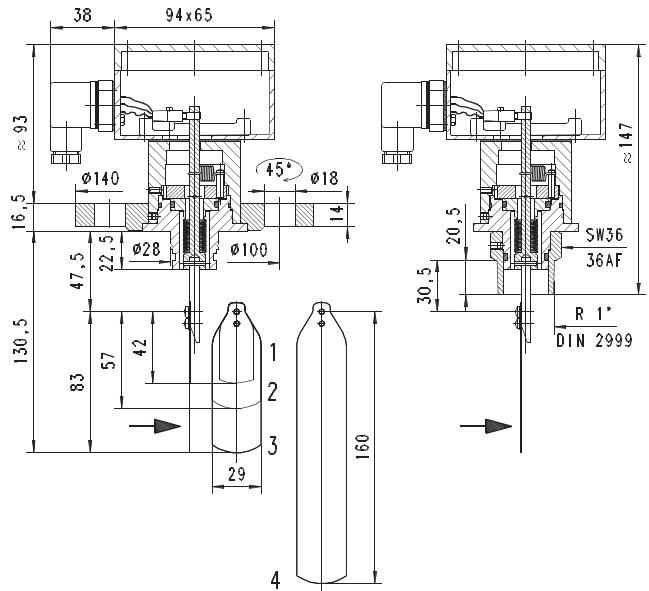

Adapt paddle 1 for DN 25.
From DN 100, adapt paddle 4:
DN 100 Paddle length 92
DN 125 Paddle length 117
DN 150 Paddle length 143
from DN 175 unshortened

Attention! Flange seal not included in scope of delivery

Handling and operation

Note

- Attention! Paddle fixing unsecured. For critical conditions (e.g. vibration), fit a bolted fixing.
- Include straight calming section of 10 x DN in inlet and outlet
- If the media are dirty, install a filter.
- It must be ensured that the values given for voltage, current, and power are not exceeded.
- When switched on, a load must be connected in series.
- The electrical details apply to ohmic loads. Capacitive and inductive loads must be operated using a protective circuit.

Loosen adjustment

Open cover, loosen the screw slightly on the micro switch fixing. Push the switch into the desired position. Retighten the screw.

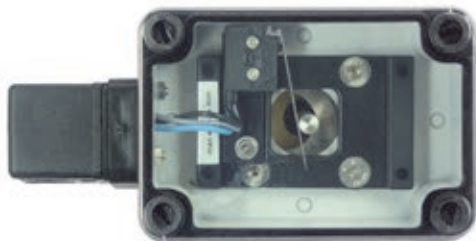

Installation recommendation

Threaded type

Use a tube with standard wall thickness as per DIN 2448

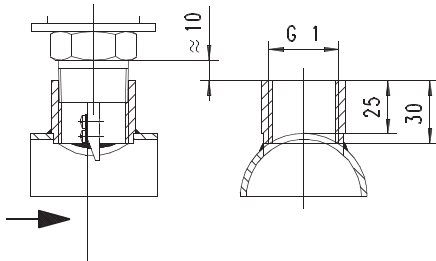

Flanged type

Use a tube with standard wall thickness as per DIN 2448

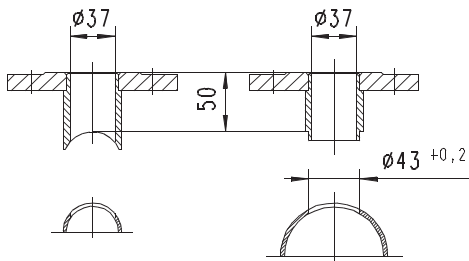

The type FL installation flanges are available as an accessory.

Ordering code

UB1 - 1. 2.

1. Process connection	
025H	threaded connection DN 25 - R 1 "
032E	flange DN 32
2. Connection material	
M	brass
K	stainless steel

Options

- Signal lamp red or red/green in the plug DIN 43650-A
- Double contact
- Aluminium hood with IP 67
- Opaque cover
- Switching ranges for oil
- Special values
- TÜV-certification 0000021402

Ordering information

- Specify direction of flow, medium, and switching range.
- For oils, state viscosity, temperature and designation (e.g. ISO VG 68) (enquire about range).

Flow Switch UBX



- Suitable for nominal sizes DN 65, DN 80 und DN 100
- Mikroschwitch with bi-level gold contact
- System connection with oval flange or male thread R 1"
- For temperature range -40 °C bis +140 °C

Characteristics

The devices work via the principle of a bellow-supported paddle which triggers directly a microswitch in case of flow.

Technical Data

Switch	Mikroschwitch
Nominal diameter	DN 65, DN 80, DN 100
Process connection	Oval flange or male thread R1"
Adjustable range (for decreasing flow)	DN 65: 6.0 m³/h ± 2.0 DN 80: 10.5 m³/h ± 2.5 DN 100: 20.5 m³/h ± 3.0
Q_{max.} (recommended)	DN 65: 33 m³/h DN 80: 45 m³/h DN 100: 65 m³/h (all values for v = 2 m/s)
Pressure rate	PN 16 bar
Medium temperature	-40..+140 °C (no superheated steam)
Ambient temperature	-40..+90 °C
Media	Water, mineral oil, silicone oil, ester oil
Connection diagram	<p>Single changeover contact (wiring 0.371-2)</p> <p>Double changeover contact (wiring 0.409-1)</p>

Switching voltage/ Switching current	max.	250 V AC/DC	A max. ohmic	A max. inductive
		125 V AC/DC	6 A	1,5 A
		24 V DC	6 A	2 A
		1 2 V DC	6 A	6 A
min.	4 V	A min.		
		1 mA		
Protection class	2 – Safety insulation			
Ingress protection	IP 65 / IP 67 (When using a permissible supply cable)			
Electrical connection	Cable gland M16x1,5			
Materials with medium contact	Brass version: CW614N vernickelt, 1.4305, 1.4310, 1.4541, FVMQ		Stainless steel version 1.4305, 1.4310, 1.4541, FVMQ	
Housing material	Die-cast aluminium			
Weight	1,3 kg			
Mounting position	Standard: horizontal flow; switching unit not recommended underneath; other installation positions are possible; the installation position affects the switching point and range.			

Dimensions

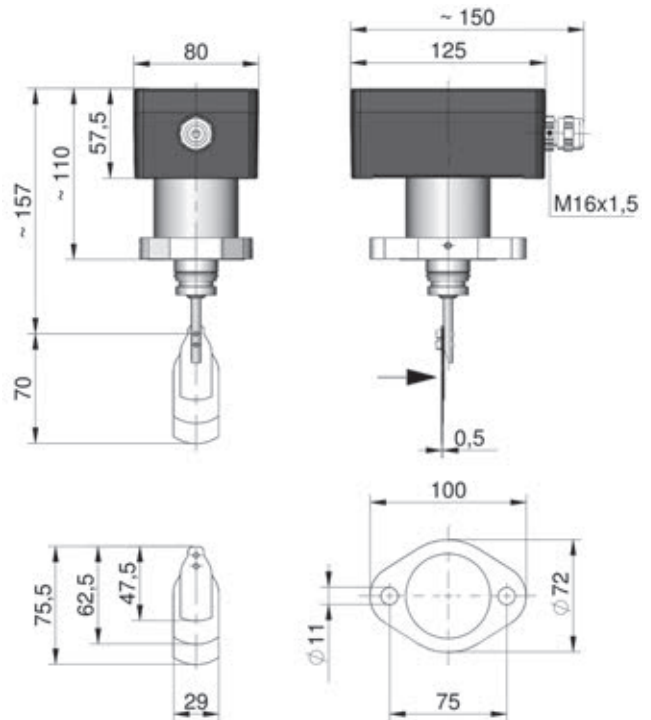

Figure shows flow switch for DN 65 with oval flange!

Attention! Process gasket not included !

Handling and operation

Notes

- Attention! Paddle fixing unsecured. For critical conditions (e.g. vibration), fit a bolted fixing.
- Include straight calming section of 10 x DN in inlet and outlet
- If the media are dirty, install a filter.
- It must be ensured that the values given for voltage, current, and power are not exceeded.
- When switched on, a load must be connected in series.
- The electrical details apply to ohmic loads. Capacitive and inductive loads must be operated using a protective circuit..

Installation recommendation

Flange design

Use a tube with standard wall thickness as per DIN 2448.

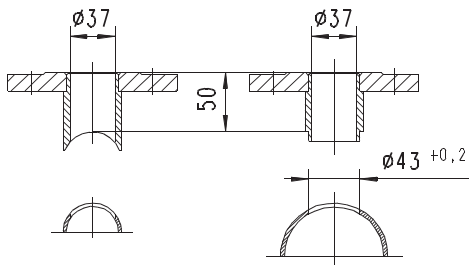

Ordering code

UBX - ^{1.} ^{2.} ^{3.}

1. Process connection	
025H	Male thread R1"
032E	Flange
2. Anschlusswerkstoff	
M	Brass
K	Stainless steel
3. Contacts	
S	Single changeover contact
D	Double changeover contact

Options

- Adjustment
- Optional temperature range -50 °C ... +50 °C
- Other process connections on request

Ordering information

- Specify direction of flow, medium, and switching range.
- For oils, state viscosity, temperature and designation (e.g. ISO VG 68) (enquire about range).

Flow Switch CRE



- Can be used from nominal width DN 25..200
- Suitable for media with ferritic particles

Characteristics

The devices function via the principle of a paddle supported by a metal bellows, and the triggering of a micro switch.

Technical data

Switch	micro switch	
Nominal width	DN 25..200	
Process connection	male thread R 1 "	
Switching range	0.19..165.7 m ³ /h	for details see table "Ranges"
Q_{max.}	up to 240 m ³ /h	
Tolerance	±15 % of full scale value	
Pressure resistance	brass construction stainless steel construction	PN 8 bar , reduced switching range PN 5 bar PN 13 bar , reduced switching range PN 5 bar
Medium temperature	-20..+120 °C	
Ambient temperature	-20..+85 °C	
Media	water (oils and aggressive media available on request)	
Wiring	changeover no. 0.374	
Switching voltage	250 V AC	
Switching current	15(8) A	
Protection class	1 - PE connection	
Ingress protection	IP 65	
Electrical connection	cable screw gland M16x1.5	
Materials medium-contact	Brass construction: CW614N, 1.4571, Tombak	Stainless steel construction: 1.4571
Non-medium-contact materials	ABS	
Weight	Brass construction: Stainless steel construction:	0.95 kg 1.1 kg

Installation location	Standard: horizontal inwards flow; switching unit not recommended underneath; other installation positions are possible; the installation position affects the switching point and range.
------------------------------	---

Ranges

Details in the table correspond to horizontal inwards flow with decreasing flow rate.

● = Standard ○ = Option for reduced switching range

DN	Switching range m ³ /h H ₂ O				Q _{max.} recommended
	Paddle 1	Paddle 1,2*	Paddle 1,2,3*	Paddle 1,2,3,4*	
25	○ 0.19 - 1.0				3.6
	● 0.55 - 2.0				
32	○ 0.24 - 1.4				6.0
	● 0.82 - 2.8				
40	○ 0.50 - 1.9				9.0
	● 1.10 - 4.0				
50	○	0.9 - 3.6			15.0
	●				
65	○	1.2 - 4.9			24.0
	●				
80	○		2.1 - 7.4		36.0
	●				
100	○		4.9 - 17.1	3.3 - 11.6	60.0
	●				
125	○		9.7 - 34.0	5.0 - 17.5	90.0
	●				
150	○		13.6 - 47.6	6.1 - 21.4	120.0
	●				
200	○		25.7 - 90.1	21.7 - 55.3	240.0
	●				

*must be used together

Dimensions

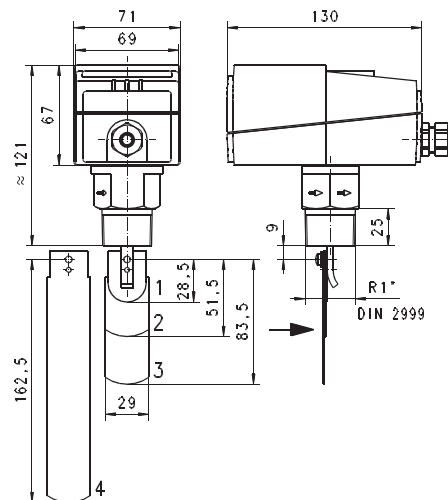

Adapt paddle 1 for DN 25.
From DN 100, adapt paddle 4:
DN 100 Paddle length 92
DN 125 Paddle length 117
DN 150 Paddle length 143
from DN 175 unshortened

Handling and operation

Note

- Attention! Paddle fixing unsecured. For critical conditions (e.g. vibration), fit a bolted fixing.
- Include straight calming section of 10 x DN in inlet and outlet
- If the media are dirty, install a filter.
- It must be ensured that the values given for voltage, current, and power are not exceeded.
- When switched on, a load must be connected in series.
- The electrical details apply to ohmic loads.
Capacitive and inductive loads must be operated using a protective circuit.

Loosen adjustment

Screw, and remove hood; set the desired switching value using the adjustment screw, and refasten the hood.

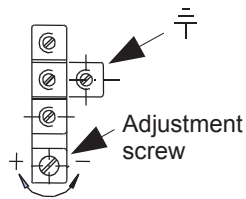

Installation recommendation

Use a tube with standard wall thickness as per DIN 2448

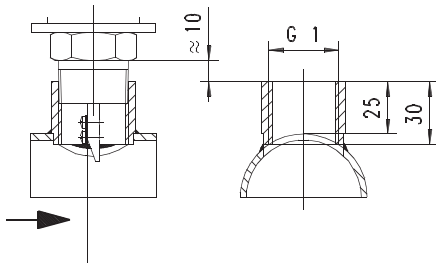

Ordering code

1. 2. 3. 4.
CRE - 025H S

○=Option

1. Process connection	
025H	threaded connection DN 25 - R 1 "
2. Connection material	
M	brass
K	stainless steel
3. Cable screw gland	
S	to the side
4. Switching range	
R	<input type="checkbox"/> reduced

Options

- TÜV certification
CRE-025HMS / CRE-025HKS TÜV.SW.14-028
CRE-025HMSR / CRE-025HKS SR TÜV.SW.14-029
- Switching ranges for oil
- Special values



Ordering information

- Specify direction of flow, medium, and switching range.
- For oils, state viscosity, temperature and designation (e.g. ISO VG 68) (enquire about range).

Flow Switch CRG



- Can be used from nominal width DN 25..200
- Suitable for media with ferritic particles.

Characteristics

The devices function via the principle of a paddle supported by a metal bellows, and the triggering of a micro switch.

Technical data

Switch	micro switch	
Nominal width	DN 25..200	
Process connection	male thread R 1 "	
Switching range	0.2..165.7 m³/h	for details see table "Ranges"
Q_{max.}	up to 240 m³/h	
Tolerance	±15 % of full scale value	
Pressure resistance	PN 11 bar	
Medium temperature	-20..+120 °C	
Ambient temperature	-20..+85 °C	
Media	water (oils and aggressive media available on request)	
Wiring	changeover no. 0.374	
Switching voltage	250 V DC	
Switching current	15(8) A	
Protection class	1 - PE connection	
Ingress protection	IP 65	
Electrical connection	cable screw gland M20x1.5	
Materials medium-contact	Brass construction: CW614N, 1.4571, Tombak	Stainless steel construction: 1.4571
Non-medium-contact materials	ABS, PC transparent	
Weight	Brass construction:	0.95 kg
	Stainless steel construction:	1.1 kg

Installation location	Standard: horizontal inwards flow; switching unit not recommended underneath; other installation positions are possible; the installation position affects the switching point and range.
------------------------------	---

Ranges

Details in the table correspond to horizontal inwards flow with decreasing flow rate.

● = Standard ○ = Option for reduced switching range

DN	Switching range m³/h H ₂ O				Q _{max.} recommended
	Paddle 1	Paddle 1,2*	Paddle 1,2,3*	Paddle 1,2,3,4*	
25	○ 0.20 - 1.0 ● 0.60 - 2.0				3.6
32	○ 0.25 - 1.4 ● 0.80 - 2.8				6.0
40	○ 0.50 - 1.6 ● 1.10 - 3.7				9.0
50	○	0.9 - 3.6 ● 2.2 - 5.7			15.0
65	○	1.2 - 4.9 ● 2.7 - 6.5			24.0
80	○		2.1 - 7.4 ● 4.3 - 10.7		36.0
100	○		4.9 - 17.1 ● 11.4 - 27.7	3.3 - 11.6 ● 6.1 - 17.3	60.0
125	○		9.7 - 34.0 ● 22.9 - 53.3	5.0 - 17.5 ● 9.3 - 25.2	90.0
150	○		13.6 - 47.6 ● 35.9 - 81.7	6.1 - 21.4 ● 12.3 - 30.6	120.0
200	○		25.7 - 90.1 ● 72.6 - 165.7	21.7 - 55.3 ● 38.6 - 90.8	240.0

*must be used together

Dimensions

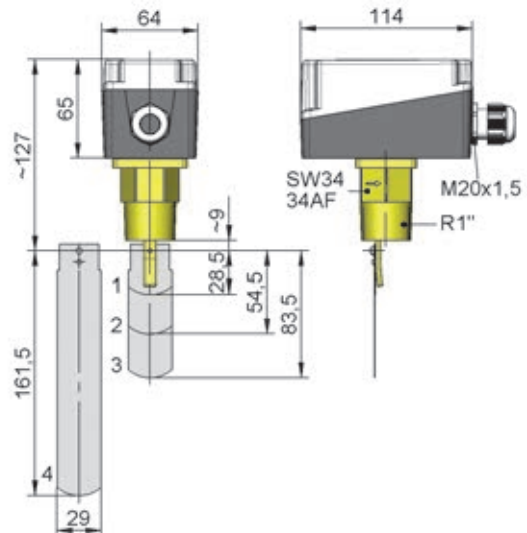

Adapt paddle 1 for DN 25.
From DN 100, adapt paddle 4:
DN 100 Paddle length 92
DN 125 Paddle length 117
DN 150 Paddle length 143

From DN 175 unshortened

Handling and operation

Note

- Attention! Paddle fixing unsecured. For critical conditions (e.g. vibration), fit a bolted fixing.
- Include straight calming section of 10 x DN in inlet and outlet
- If the media are dirty, install a filter.
- It must be ensured that the values given for voltage, current, and power are not exceeded.
- When switched on, a load must be connected in series.
- The electrical details apply to ohmic loads. Capacitive and inductive loads must be operated using a protective circuit.

Loosen adjustment

Screws, and remove hood; set the desired switching value using the adjustment screw, and refasten the hood.

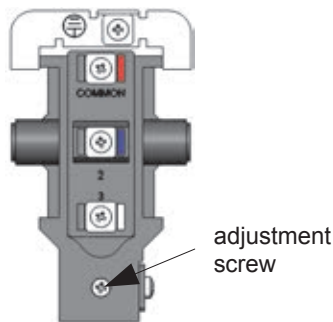

Installation recommendation

Use a tube with standard wall thickness as per DIN 2448

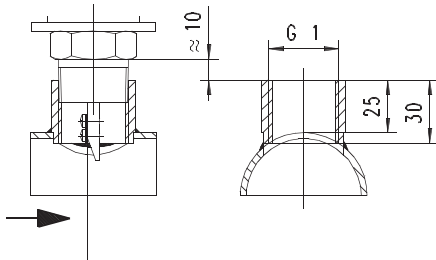

Ordering code

CRG -

1.	2.	3.	4.
025H		S	

○=Option

1. Process connection	
025H	threaded connection DN 25 - R 1 "
2. Connection material	
M	brass
K	stainless steel
3. Cable screw gland	
S	to the side
4. Switching range	
R	<input type="radio"/> reduced

Options

- Switching ranges for oil
- Special values

Ordering information

- Specify direction of flow, medium, and switching range.
- For oils, state viscosity, temperature and designation (e.g. ISO VG 68) (enquire about range).

Flow Switch VM-...E



- Can be used from nominal width DN 40..200
- Precise, stepless adjustment of the switching value

Characteristics

The paddle movement of the flow switch is transmitted via a magnetic coupling to an adjustably arranged micro switch.

Technical data

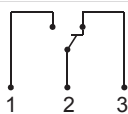
Switch	micro switch	
Nominal width	DN 40..200	
Process connection	installation flange DIN 2527 DN 32 PN 16 sealing surface as per DIN 2526 form C	
Switching range	40..3600 l/min	for details see Table "Ranges and dimensions"
Q_{max.}	up to 5400 l/min	
Tolerance	±5 % of full scale value	
Pressure resistance	PN 16 bar	
Medium temperature	-20..+90 °C, optionally -20..+200 °C, type VMX on request	
Ambient temperature	-20..+70 °C	
Media	water (oils available on request)	
Wiring	changeover no. 0.213	
Switching voltage	max. 250 V AC	
Switching current	max. 5 A	
Protection class	2 - safety insulation	
Ingress protection	IP 65	
Electrical connection	plug DIN 43650-A / ISO 4400	
Materials medium-contact	<i>Brass construction:</i> Rg 5, CW614N nick- elled, 1.4305, 1.4301, 1.4310, 1.4571, NBR, hard ferrite	<i>Stainless steel construction:</i> 1.4305, 1.4301, 1.4310, 1.4571, FKM, hard ferrite
Non-medium-contact materials	ABS, PA	

Weight	DN 40..150 DN 200	3.0 kg 3.5 kg
Installation location	Standard: horizontal inwards flow; display downwards and inwards flow from above not recommended; other installation positions are possible; the installation position affects the switching point and display range.	

Ranges and dimensions

Details in the table correspond to horizontal inwards flow with decreasing flow rate.

DN	Switching range l/min H ₂ O	Q _{max.} recommended	Types	Paddle form	L
DN 40	40 - 150	250	VM-040E.150	1	93
DN 50	50 - 150	450	VM-050E.150		104
	100 - 300		VM-050E.300	96	
DN 65	125 - 375	550	VM-065E.300	1	115
			VM-065E.375		90
DN 80	150 - 400	900	VM-080E.400	1	118
	200 - 600		VM-080E.600		115
DN 100	250 - 750	1400	VM-100E.750	2	158
	300 - 900		VM-100E.900		122
DN 150	500 - 1500	2700	VM-150E.1500	1	198
	600 - 1800		VM-150E.1500		198
DN 200	1000 - 3000	5400	VM-200E.3000	1	213
	1200 - 3600		VM-200E.3600		

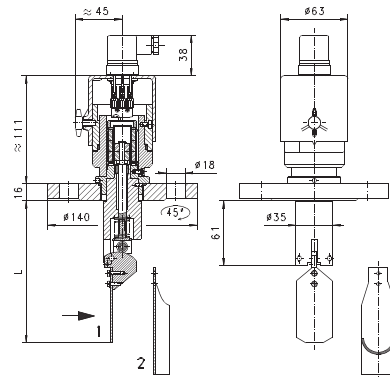

Attention! Flange seal not included in scope of delivery

Handling and operation

Note

- Include straight calming section of 10 x DN in inlet and outlet
- If the media are dirty, install a filter (use magnetic filter for ferritic components).
- It must be ensured that the values given for voltage, current, and power are not exceeded.
- When switched on, a load must be connected in series.
- The electrical details apply to ohmic loads. Capacitive and inductive loads must be operated using a protective circuit.

Adjustment

To adjust the switching point, the fixing screw for the switching head must be loosened. The switching head can then be rotated. Turning to the right increases the switching point, and vice-versa. Then retighten the fixing screw.



Installation recommendation

Use a tube with standard wall thickness as per DIN 2448
The type FL installation flanges are available as an accessory.

Ordering code

VM - 1. 2. 3. 4. 5.
 E

1. Nominal width									
040	DN 40								
050	DN 50								
065	DN 65								
080	DN 80								
100	DN 100								
150	DN 150								
200	DN 200								
2. Process connection									
E	installation flange								
3. Connection material									
M	brass								
K	stainless steel								
4. Switching range H₂O for horizontal inwards flow									
150	40 - 150 l/min								●
	50 - 150 l/min								●
300	100 - 300 l/min							●	●
375	125 - 375 l/min							●	
450	150 - 450 l/min							●	
600	200 - 600 l/min							●	
750	250 - 750 l/min							●	
900	300 - 900 l/min							●	
1500	500 - 1500 l/min							●	
1800	600 - 1800 l/min							●	
3000	1000 - 3000 l/min							●	
3600	1200 - 3600 l/min							●	
5. Optional for ATEX									
A	for switching head ATEX A-V2 or A-V3 (The switching head is ordered in addition)								

Options

- Special plugs, Tuchel / Harting
- Signal lamp red or red / green in the plug DIN 43650-A
- Signal lamp, miscellaneous
- Temperature display
- Temperature monitoring
- Temperature up to 150 °C
- Metal cap
- Gold contact micro switch 125 V AC / 30 V DC, 100 mA
- Germanischer Lloyd
- Switching ranges for oil
- Special values

Ordering information

- Specify direction of flow, medium, and switching range.
- For oils, state viscosity, temperature and designation (e.g. ISO VG 68) (enquire about range).

Switching Head A-V2

pi-ho_ze-a-v3_d.pdf

For devices VM-



Dimensions

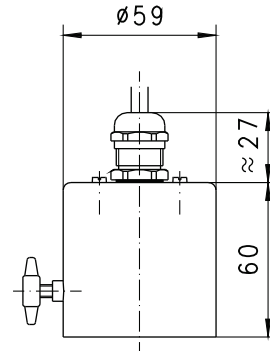

- I M1 Ex ia Ma
- II 1G Ex ia IIC T4 Ga
- II 1D Ex ia IIIC T135°C Da

Characteristics

Intrinsically safe switching head with reed switch and ATEX approval, for the VM range of devices, for use in intrinsically safe power circuits.

Technical data

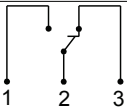
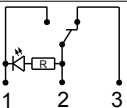
Switch	micro switch
Medium temperature	-20..+90 °C
Ambient temperature	-20..+50 °C
Weight	0.5 kg additionally
Without diode	
Wiring	changeover no. 0.213 
Switching voltage	max. 30 V
Switching current	max. 1.5 A
Switching capacity	max. 50 W
Protection class	3 -protective extra low voltage
With diode	
Wiring	changeover with diode No. 0.208 
Switching voltage	max. 15 V, 28 V or 36 V
Switching current	max. 1.5 A
Switching capacity	max. 50 W
Protection class	3 - protective extra low voltage
Ingress protection	IP 65
Electrical connection	cable 2.5 m, other cable lengths optionally available

Handling and operation

Note

- For use only in intrinsically safe power circuits; provide a suitable isolating amplifier.
- Cable lengths max. 5 m.
- It must be ensured that the values given for voltage, current, and power are not exceeded.
- When switched on, a load must be connected in series.
- The electrical details apply to ohmic loads. Capacitive, inductive and lamp loads must be operated using a protective circuit.

Adjustment

To adjust the switching point, the fixing screw for the switching head must be loosened. The switching head can then be rotated. Turning to the right increases the switching point, and vice-versa. Then retighten the fixing screw.

Ordering code

The base device is ordered, e.g. VM-015GR020A with switching head e.g. A-V2-1.

A-V2 - 1.

1. Wiring - switching voltage	
1	wiring no. 0.213 - 30 V
2	wiring no. 0.208 - 15 V
3	wiring no. 0.208 - 28 V
4	wiring no. 0.208 - 36 V

Use for devices

Switching head	Device type
A-V2	VM-...



Switching Head A-V3

For devices VM-



- II 2G Ex d IIC T6 Gb

Characteristics

Switching head with pressure-resistant encapsulation and ATEX approval for the VM range of devices.

Technical data

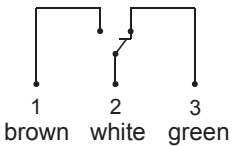
Switch	micro switch
Medium temperature	-20..+90 °C
Ambient temperature	-20..+50 °C
Weight	0.5 kg additionally
Wiring	changeover no. 0.283 
Switching voltage	max. 250 V AC
Switching current	max. 5 A
Protection class	2 - safety insulation
Ingress protection	IP 65
Electrical connection	cable 2.5 m, other cable lengths optionally available

Dimensions

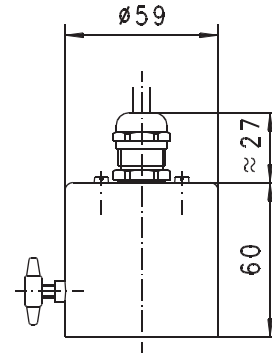

Handling and operation

Note

- Cable lengths max. 5 m.
- It must be ensured that the values given for voltage, current, and power are not exceeded.
- When switched on, a load must be connected in series.
- The electrical details apply to ohmic loads. Capacitive, inductive and lamp loads must be operated using a protective circuit.

Adjustment

To adjust the switching point, the fixing screw for the switching head must be loosened. The switching head can then be rotated. Turning to the right increases the switching point, and vice-versa. Then retighten the fixing screw.

Ordering code

The base device is ordered, e.g. VM-015GR020A with switching head e.g. A-V3-1.

A-V3 - ^{1.} 1

1. Wiring	
1	No. 0.283

Use for devices

Switching head	Device type
A-V3	VM-...



Flow Meter UZ



- Monitor and display
- Simple switching point adjustment by means of drag indicator
- Insensitive to dirt
- Suitable for media with ferritic particles.

Characteristics

With the UZ paddle flow display, the flow strength of the medium presses the paddle against a spring force. Hermetically separated by the bellows, the paddle's deflection is transmitted to a display movement, and may optionally be monitored with an adjustable micro switch. There is no magnet in the area of flow.

Technical data

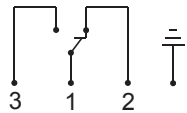
Switch	optionally micro switch	
Nominal width	DN 15..50	
Process connection	female thread G 1/2..G 2	
Metering range	2..500 l/min	for details see table "Ranges"
Q_{max.}	to 600 l/min	
Tolerance	±3 % of full scale value	
Pressure resistance	Dynamic PN 6 bar	Static PN 16 bar
Medium temperature	-20..+100 °C	
Ambient temperature	-20..+70 °C	
Media	water (oils and aggressive media available on request)	
Wiring	changeover no. 0.342	
Switching voltage	max. 250 V AC	
Switching current	max. 5 A	
Protection class	2	
Ingress protection	IP 65	
Electrical connection	plug DIN 43650-A / ISO 4400	

Materials medium-contact	<i>Brass construction:</i> CW614N nickelled, 1.4571, 1.4305 <i>Stainless steel construction:</i> 1.4571, 1.4305
Non-medium-contact materials	CW614N chromed, steel chromed, acrylic, FKM
Weight	see table "Dimensions and weights"
Installation location	Standard: horizontal inwards flow; display downwards not recommended; other installation positions are possible; the installation position affects the switching point and display range.

Ranges

Details in the table correspond to horizontal inwards flow with increasing flow rate.

Flow from the left.

G	Nominal width	Metering range l/min H ₂ O	Q _{max.} recommended	Type
G 1/2	DN 15	3 - 50	60	UZ-015G.050
G 3/4	DN 20	4 - 60	100	UZ-020G.060
G 1	DN 25	10 - 100	200	UZ-025G.060
				UZ-025G.100
G 1 1/4	DN 32	20 - 200	300	UZ-032G.100
				UZ-032G.200
G 1 1/2	DN 40	10 - 300	400	UZ-040G.200
				UZ-040G.300
				UZ-040G.300
G 2	DN 50	20 - 300	600	UZ-050G.300
		30 - 500		UZ-050G.500

Special ranges are available

Optional: Flow from the right (please specify when ordering)

G	Nominal width	Metering range l/min H ₂ O	Q _{max.} recommended	Type
G 1/2	DN 15	2 - 35	60	UZ-015G.035
G 3/4	DN 20	4 - 45	100	UZ-020G.045
		6 - 70		UZ-020G.070
G 1	DN 25	4 - 50	200	UZ-025G.050
		10 - 100		UZ-025G.100
G 1 1/4	DN 32	20 - 200	300	UZ-032G.100
				UZ-032G.200
G 1 1/2	DN 40	10 - 300	400	UZ-040G.200
				UZ-040G.300
G 2	DN 50	60 - 300	600	UZ-050G.300
		100 - 500		UZ-050G.500

Special ranges are available

Dimensions and weights

G	Types	H	L	SW	X	Weight kg
G 1/2	UZ-015G.	201	70	30	16	2.0
G 3/4	UZ-020G.	206	74	36	18	
G 1	UZ-025G.	201	87	46	19	2.5
G 1 1/4	UZ-032G.	209	104	55	22	3.0
G 1 1/2	UZ-040G.	215	111	65	24	4.5
G 2	UZ-050G.	227	130	70	28	5.0

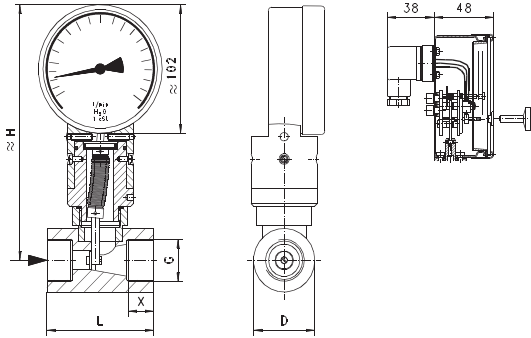

Handling and operation

Note

- Include straight calming section of 5 x DN in inlet and outlet
- If the media are dirty, install a filter.
- It must be ensured that the values given for voltage, current, and power are not exceeded.
- When switched on, a load must be connected in series.
- The electrical details apply to ohmic loads. Capacitive and inductive loads must be operated using a protective circuit.

Adjustment

The micro switch (optional) is adjusted by means of the knurled adjusting screw provided. The screw allows the drag indicator to be set to the desired switching value. The value displayed corresponds to a switching point for a decreasing flow rate.



Ordering code

UZ 1. 2. 3. **G** 4. 5.

○=Option

1. Additional devices					
-	only analog display				
M-	with integrated micro switch				
P-	○ with potentiometer				
M2-	○ with 2 x normally open (n.o.)				see „Additional devices for UZ“
M3-	○ with 2 x normally closed (n.c.)				
2. Nominal width					
015	DN 15 - G 1/2				
020	DN 20 - G 3/4				
025	DN 25 - G 1				
032	DN 32 - G 1 1/4				
040	DN 40 - G 1 1/2				
050	DN 50 - G 2				
3. Process connection					
G	female thread				
4. Connection material					
M	brass				
K	stainless steel				
5. Metering range H ₂ O for horizontal inwards flow					
035	from the right	2 - 35 l/min			●
045	from the right	4 - 45 l/min			●
050	from the left	3 - 50 l/min			●
	from the right	4 - 50 l/min		●	
060	from the left	4 - 60 l/min		●	●
070	from the right	6 - 70 l/min			●
100	from left/right	10 - 100 l/min		●	●
	from left/right	20 - 200 l/min		●	●
300	from left/right	10 - 300 l/min		●	
	from the left	20 - 300 l/min		●	
	from the right	60 - 300 l/min		●	
500	from the left	30 - 500 l/min		●	
	from the right	100 - 500 l/min		●	

Options

- Metering ranges for oil or gas
- Special values
- Gold contact
 - min: 5 V DC, 1 mA
 - max: 125 V AC, 30 V DC, 1 A
- Special Harting plug

Ordering information

- Specify direction of flow, medium, and metering range.
- For oils. State viscosity, temperature and designation (e.g. ISO VG 68) (enquire about metering range).
- For gases, state pressure (relative or absolute), temperature and medium (e.g. air) (request metering range)

Additional Devices For UZ

UZP - 10 kOhm potentiometer

Technical data

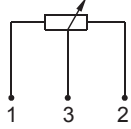
Switch/sensor	potentiometer
Wiring	no. 0.269 
Switching voltage	max. 50 V
Switching current	max. 1 mA
Switching capacity	Max. 1,5 W
Protection class	2 - safety insulation
Additional Tolerance	±3 %
Resistance tolerance	±1 %
Linearity tolerance	±0,3 %
Ingress protection	IP 60
Electrical connection	plug Hirschmann G 4
Additional Weight	0.3 kg

Dimensions

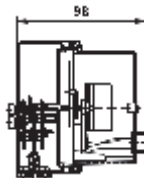

UZM2 - 2-pole normally open (n.o.)

Technical data

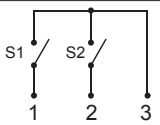
Switch/sensor	micro switch
Wiring	2 x normally open (n.o.) no. 0.268 
Switching voltage	max. 250 V AC
Switching current	max. 0.6 A
Switching capacity	max. 50 VA
Protection class	2 - safety insulation
Ingress protection	IP 60
Electrical connection	plug Hirschmann G 4
Additional Weight	0.3 kg

Dimensions

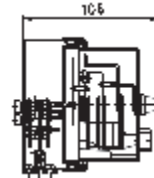

UZM3 - 2-pole normally open (n.o.)

Technical data

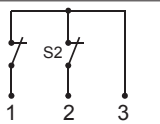
Switch/sensor	micro switch
Wiring	2 x normally closed (n.c.) wiring 0.285 
Switching voltage	max. 250 V AC
Switching current	max. 0.6 A
Switching capacity	max. 50 VA
Protection class	2 - safety insulation
Ingress protection	IP 60
Electrical connection	plug Hirschmann G 4
Additional Weight	0.3 kg

Dimensions

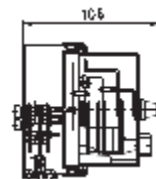

Flow Meter TZ1-...E



- Large analog display
- Monitor and display
- Simple adjustment by means of drag indicator
- Can be used from nominal width DN 40..100

Characteristics

Mechanical flow meter, for fluid or gaseous media, with no-contact triggering of an display device with 270 ° pointer deflection. Robust construction in brass or stainless steel.

Technical data

Switch	optionally micro switch	
Nominal width	DN 40..100	
Process connection	installation flange DIN 2527 DN 32 PN 16 sealing surface as per DIN 2526 form C	
Metering range	50..1050 l/min	for details see table "Ranges and dimensions"
Q_{max.}	up to 1400 l/min	
Tolerance	±5 % of full scale value	
Pressure resistance	PN 16 bar	
Medium temperature	-20..+90 °C, optionally -20..+200 °C, type TZ1X on request	
Ambient temperature	-20..+70 °C	
Media	water (oils available on request)	
Wiring	changeover no. 0.342	
Switching voltage	max. 250 V AC	
Switching current	max. 5 A	
Protection class	2 - safety insulation	
Ingress protection	IP 65	
Electrical connection	plug DIN 43650-A / ISO 4400	

Materials medium-contact	<i>Brass construction:</i> Rg 5, CW614N nickelled, 1.4305, 1.4301, 1.4310, 1.4571, NBR, hard ferrite	<i>Stainless steel construction:</i> 1.4305, 1.4301, 1.4310, 1.4571, FKM, hard ferrite
Non-medium-contact materials	CW614N chromed, steel chromed, Acrylic, NBR	
Weight	3 kg	
Installation location	Standard: horizontal inwards flow; display downwards and inwards flow from above not recommended; other installation positions are possible; the installation position affects the switching point and display range.	

Ranges and dimensions

Details in the table correspond to horizontal inwards flow with increasing flow rate.

DN	Metering range l/min H ₂ O	Q _{max.} Recom- mended	Types	Paddle form	L
DN 40	50 - 250	450	TZ1-040G.250	1	93
	100 - 350		TZ1-040G.350		87
DN 50	80 - 350	450	TZ1-050G.350	1	98
	100 - 450		TZ1-050G.450		
DN 65	100 - 350	550	TZ1-065G.350	1	111
	150 - 500		TZ1-065G.500		101
DN 80	130 - 450	900	TZ1-080G.450	1	126
	200 - 600		TZ1-080G.600		112
DN 100	300 - 800	1400	TZ1-100G.800	2	158
	350 - 1050		TZ1-100G.1050		148

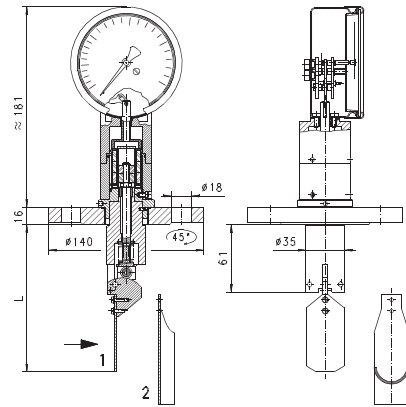

Attention! Flange seal not included in scope of delivery

Handling and Operation

Note

- Include straight calming section of 10 x DN in inlet and outlet
- If the media are dirty, install a filter (use magnetic filter for ferritic components).
- It must be ensured that the values given for voltage, current, and power are not exceeded.
- When switched on, a load must be connected in series.
- The electrical details apply to ohmic loads. Capacitive and inductive loads must be operated using a protective circuit.

Loosen adjustment

The microswitch (optional) is adjusted by means of the knurled adjusting screw provided. The screw allows the drag indicator to be set to the desired switching value. The value displayed corresponds to a switching point for a decreasing flow rate.



Installation recommendation

Use a tube with standard wall thickness as per DIN 2448

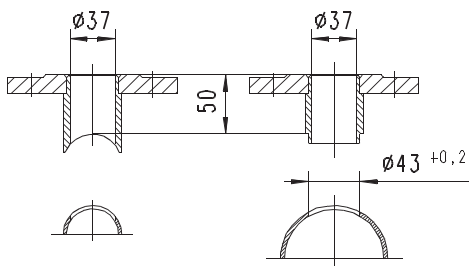

The type FL installation flanges are available as an accessory.

Ordering code

TZ1 1. 2. 3. 4. 5.

○=Option

1. Additional devices				
-	only analog display			
M-	with integrated micro switch			
P-	○ with potentiometer	see „Additional devices for TZ1“		
M2-	○ with 2 x normally open (n.o.)			
M3-	○ with 2 x normally closed (n.c.)			
2. Nominal width				
040	DN 40			
050	DN 50			
065	DN 65			
080	DN 80			
100	DN 100			
3. Process connection				
E	installation flange			
4. Connection material				
M	brass			
K	stainless steel			
5. Metering range H₂O for horizontal inwards flow				
250	50 - 250 l/min			●
350	80 - 350 l/min			●
	100 - 350 l/min		●	●
450	100 - 450 l/min			●
	130 - 450 l/min		●	
500	150 - 500 l/min			●
600	200 - 600 l/min			●
800	300 - 800 l/min		●	
1050	350 - 1,050 l/min			

Options

- Metering ranges for oil
- Special values
- Gold contact
 - min: 5 V DC, 1 mA
 - max: 125 V AC, 30 V DC, 1 A
- Special Harting plug

Ordering information

- Specify direction of flow, medium, and metering range.
- For oils. State viscosity, temperature and designation (e.g. ISO VG 68) (enquire about metering range).

Additional Devices for TZ1

TZ1P - 10 kOhm potentiometer

Technical data

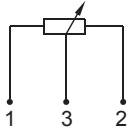
Switch/sensor	potentiometer
Wiring	no. 0.269 
Switching voltage	max. 50 V
Switching current	max. 1 mA
Switching capacity	max. 1.5 W
Protection class	2 - safety insulation
Additional Tolerance	±3 %
resistance tolerance	±1 %
Linearity tolerance	±0,3 %
Ingress protection	IP 60
Electrical connection	plug Hirschmann G 4
Additional Weight	0.3 kg

Dimensions

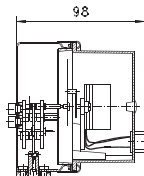

TZ1M2 - 2-pole normally open (n.o.)

Technical data

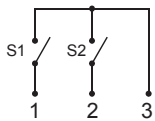
Switch/sensor	micro switch
Wiring	2 x normally open (n.o.) no. 0.268 
Switching voltage	max. 250 V AC
Switching current	max. 0.6 A
Switching capacity	max. 50 VA
Protection class	2 -safety insulation
Ingress protection	IP 60
Electrical connection	plug Hirschmann G 4
Additional Weight	0.3 kg

Dimensions

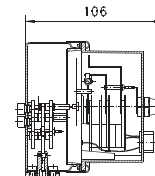

TZ1M3 - 2-pole normally closed (n.c.)

Technical data

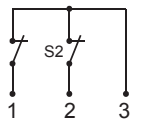
Switch/sensor	Micro switch
Wiring	2 x normally closed (n.c.) wiring 0.285 
Switching voltage	max. 250 V AC
Switching current	max. 0.6 A
Switching capacity	max. 50 VA
Protection class	2 -safety insulation
Ingress protection	IP 60
Electrical connection	plug Hirschmann G 4
Additional Weight	0.3 kg

Dimensions

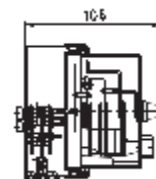

Special connections

Examples:



UM3K / UR3K
with soldered fitting



UB1
with flange DIN 2558

Customer-specific connections are available e.g. soldered fittings, male thread, female thread NPT, hose connections or system connections.

Temperature up to 250 °C

VMX-
TZ1X-



In order to operate in a higher temperature range, a special device series with an additional cooling element is available. Please request documentation.

Plug DIN 43650-A / ISO 4400 with diodes



Diode red

Wiring	changeover with diode No. 0.208	
Switching voltage	max. 12 V AC, 24 V AC, 48 V AC, 115 V DC or 230 V DC (when ordering please state)	

Red / green diode

Wiring	changeover with diode No. 0.347	
Switching voltage	max. 12 V AC, 24 V AC, 48 V AC, 115 V DC or 230 V DC (when ordering please state)	

Filter

Type ZV



Type ZE



The HONSBERG filters are offered for the protection of the devices from dirt or as independent components for coarse and fine filtration of liquids.

For more information, see additional product information.

Flange connection FL



Characteristics

Installation flange with weld-on nozzle for the appropriate installation of flow monitors and measuring devices. Can be combined with all devices with installation flange according to DIN 2526, PN 16, DN 32.

Technical data

Flange	DIN 2527, PN 16, DN 32	
Seal surface	DIN 2526 Form C	
Flat seal	Ø82 / 43 x 2 Novapress 200	
Screw	Hexagon screw DIN EN 24017 M16x50-5.6	
Nut	Hexagon nut DIN EN 24032 M16-5	
Pressure	PN 16	
Medium temperature	-40..+200 °C	
Ambient temperature	-40..+200 °C	
Materials medium-contact	Steel construction: RSt 37 Novapress 200 Steel 5.6 + 5	Stainless steel construction: 1.4305 Novapress 200 Steel 5.6 + 5
Weight	2.3 kg	

Dimensions and weights

For	Types	ØD	H
DN 40	FL-032.040	48.3	65
DN 50	FL-032.050	60.3	61
DN 65	FL-032.065	76.1	57
DN 80 - 300	FL-032.080	-	58

DN 40 - 65

DN 80 - 500

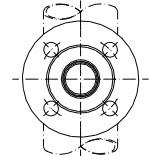
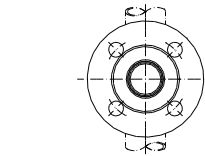
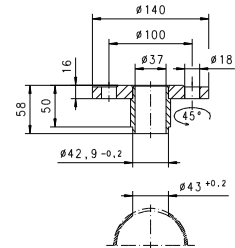
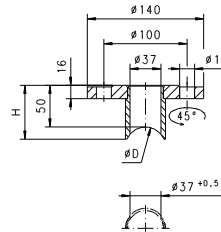

Ordering code

FL -

○=Option

1. Flange size	032	DN 32, PN 16, flange DIN 2527
3. Construction material	S	steel
	K ○	stainless steel
4. For nominal width	040	DN 40
	050	DN 50
	065	DN 65
	080	DN 80 - 300

Round plug connector 4-pin



- 1 → brown
- 2 → white
- 3 → blue
- 4 → black

Ordering code

Packaged

1. 2. 3. 4. 5.
K ○= Option

1. Number of pins	04	4-polig
2. Cable material	PU-	PUR
3. Cable length	02	2 m
	05	5 m
	10	10 m
		Others on request
4. Shielding	S	shielding applied to coupling
	U	unshielded
	N ○	shielding not applied to coupling
5. Steckerabgang	G	straight
	W	elbow 90 °



Your direct contact to us



+49 2191 9672-0



info@ghm-group.de

Headquarters

GHM Messtechnik GmbH
GHM GROUP CORPORATE
Tenter Weg 2-8
42897 Remscheid | GERMANY
Phone +49 2191 9672-0
Fax +49 2191 9672-40
info@ghm-group.de
www.ghm-group.de

Center of Competence

GHM Messtechnik GmbH
GHM GROUP – Greisinger
Hans-Sachs-Straße 26
93128 Regenstein | GERMANY
Phone +49 9402 9383-52
Fax +49 9402 9383-33
info@greisinger.de
www.greisinger.de

GHM Messtechnik GmbH
GHM GROUP – Honsberg
Tenter Weg 2-8
42897 Remscheid | GERMANY
Phone +49 2191 9672-0
Fax +49 2191 9672-40
info@ghm-group.de
www.ghm-group.de

GHM Messtechnik GmbH
GHM GROUP – Martens
Kiebitzhörn 18
22885 Barsbüttel | GERMANY
Phone +49 40 67073-0
Fax +49 40 67073-288
info@ghm-group.de
www.ghm-group.de

GHM Messtechnik GmbH
GHM GROUP – Imtron
Carl-Benz-Straße 11
88696 Owingen | GERMANY
Phone +49 7551 9290-0
Fax +49 7551 9290-90
info@ghm-group.de
www.ghm-group.de

Delta OHM S.r.l. a socio unico
GHM GROUP – Delta OHM
Via Marconi 5
35030 Caselle di Selvazzano
Padova (PD) | ITALY
Phone +39 049 8977150
info@deltaohm.com
www.deltaohm.com

Valco srl
GHM GROUP – Val.co
Via Rovereto 9/11
20014 S. Ilario di Nerviano
Milano (MI) | ITALY
Phone +39 0331 53 59 20
valco@valco.it
www.valco.it

GHM GROUP International

Austria

GHM Messtechnik GmbH
Office Austria
Breitenseer Str. 76/1/36
1140 Vienna | AUSTRIA
Phone +43 660 7335603
a.froestl@ghm-messtechnik.de
www.ghm-group.de

Brazil & Latin America

GHM Messtechnik Do Brasil Ltda
Av. José de Souza Campos,
1073, cj 06 | Campinas, SP
13025 320 | BRAZIL
Phone +55 19 98275 0069
info@grupoghm.com.br

Czech Republic / Slovakia

GHM Greisinger s.r.o.
Ovci hajek 2 / 2153
158 00 Prague 5
Nové Butovice | CZECH REPUBLIC
Phone +420 251 613828
Fax +420 251 612607
info@greisinger.cz
www.greisinger.cz

Denmark

GHM Maaleteknik ApS
Maarslet Byvej 2
8320 Maarslet | DENMARK
Phone +45 646492-00
Fax +45 646492-01
info@ghm.dk
www.ghm.dk

France

GHM GROUP France SAS
Parc des Pivolle
9 Rue de Catalogne
69150 Décines (Lyon) | FRANCE
Phone +33 6 60 32 06 35
contact@ghm-group.fr
www.ghm-group.fr

India

GHM Messtechnik India Pvt Ltd.
209 | Udyog Bhavan
Sonowala Road | Gregaon (E)
Mumbai - 400 063 | INDIA
Phone +91 22 40236235
info@ghmgroup.in
www.ghmgroup.in

Italy

Sales Greisinger & Delta OHM
GHM GROUP – Delta OHM
Via Marconi 5
35030 Caselle di Selvazzano
Padova (PD) | ITALY
Phone +39 049 8977150
info@deltaohm.com

Italy

Sales Honsberg, Martens, Val.co
GHM GROUP – Val.co
Via Rovereto 9/11
20014 S. Ilario di Nerviano
Milano (MI) | ITALY
Phone +39 0331 53 59 20
alessandro.perego@valco.it

Netherlands

GHM Meettechnik BV
Zeeltweg 30
3755 KA Eemnes
NETHERLANDS
Phone +31 35 53805-40
Fax +31 35 53805-41
info@ghm-nl.com
www.ghm-nl.com

South Africa

GHM Messtechnik SA (Pty) Ltd
16 Olivier Street
Verwoerdpark, Alberton 1453
SOUTH AFRICA
Phone +27 74 4590040
j.grobler@ghm-sa.co.za



Visit us: www.ghm-group.de