



A1 SERIES FLOWMETERS, ALUMINUM OPTION

FLOMEC® A1 Series Meters are designed as self-contained, battery-powered units. Select the A1 Series when you need an accurate meter for thin petroleum-based fluid applications.

- Available in Aluminum
- Available in three sizes
- Designed for thin petroleum based fluids

FEATURES / BENEFITS

- Unique package combines Turbine and LCD into a self-contained, compact, economical meter
- Local Display Computer features: 2 Non-Volatile Totals (Batch Total = Resettable, Total = Non-resettable) and Rate of Flow
- Output capabilities available to communicate with process control equipment
- Lightweight, compact design allows for easy installation
- AAA Alkaline battery life: 2 years
- 12 selectable engineering units (gallons or liters are standard defaults)
- Factory calibration

APPLICATIONS

- Fuel Transfer
- Batching / Blending
- Fuel Products

PRODUCT CONFIGURATION

1 PRODUCT IDENTIFIER:

A1 = Electronic Digital Meter

2 ELECTRONIC CHOICE:

Computer Display, Meter Mounted

Q9 = Q9 2-Button Computer

*Computer Display & Module, Meter Mounted**

P9 = Q9 2-Button Computer w/Pulse Out Module, includes External Power and 10 ft. of Cable

42 = Q9 2-Button Computer w/4-20mA Module and 10 ft. of Cable

*Module, Meter Mounted (No Display)**

PO = Pulse Out (Unscaled) Conditioned Signal Module w/Cable

Retrofit Computer Kit (Display Only)

R9 = Q9 2-Button Computer Retrofit Kit (Replaces Q9 Display)

No Electronics - Turbine Only

XX = No Electronics - Turbine Only

**All Electronics Approvals Void*

3 CALIBRATION:

GM = Factory Default Calibration in Gallons

LM = Factory Default Calibration in Liters

XX = No Computer

4 TURBINE SIZE:

A025 = Aluminum - Low Flow

A100 = Aluminum - 1 inch

A200 = Aluminum - 2 inch

X### = No Turbine**

***When ordering Display Only, the ### should be the turbine size.*

5 FITTING TYPE:

N = NPT (Female)

I = ISO (Female) BSPT

B = BSPP Female

X = No Turbine

6 PACKAGING:

*With FM, ATEX & IEC Approval for **HAZARDOUS AREA***

A1 = Standard or Low Flow, 1 inch (w/Q9 & R9 Electronics Choice)

A2 = Standard, 2 inch (w/Q9 & R9 Electronics Choice)

B1 = Standard or Low Flow, 1 inch Turbine Only

B2 = Standard, 2 inch Turbine Only

B3 = Display Only

*Non-Approved Version - **SAFE AREA ONLY***

C2 = Low Flow through 2 inch Turbines (w/P9, 42, & PO Electronics Choice)

1 2 3 4 5 6
---->>>> A1 Q9 GM A100 N A1

APPROVALS†



IP65



†All A1 Series Q9 Displays have the CE, NEMA 4, and IP65 approval.

SPECIFICATIONS

Meter Sizes Available:		A025 (Low Flow), A100 (1 inch), A200 (2 inch)	
Design Type:	A025	Paddlewheel	
	A100	Turbine	
	A200	Turbine	
Fitting Size / Fitting Type:	A025	1 inch / NPT, ISO ⁺ or BSPP (Female)	
	A100	1 inch / NPT, ISO ⁺ or BSPP (Female)	
	A200	2 inch / NPT, ISO ⁺	
Flow Range:	A025	0.3 - 3 GPM	1 - 11 L/min
	A100	3 - 50 GPM	11 - 190 L/min
	A200	30 - 300 GPM	114 - 1,135 L/min
Accuracy (% of Reading):		A025: Application Dependent ¹	
		A100, A200: ± 1.5%	
Repeatability:	A025	± 1.0%	
	A100	± 0.2%	
	A200	± 0.2%	

⁺ISO 7 Designation is RC.

¹Accuracy can vary up to ± 5% depending on installation and fluid type. Field calibration is recommended for best accuracy.

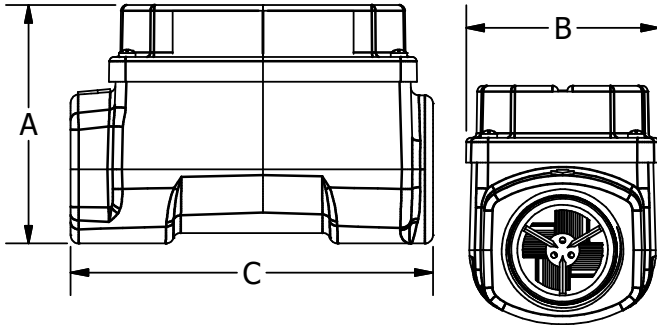

DIMENSIONS

	A025, 1 in. Low Flow	A100, 1 in.	A200, 2 in.
A = Height*	2.5 in. (6.3 cm)	2.5 in. (6.3 cm)	4.25 in. (11.4 cm)
B = Width	2.0 in. (5.1 cm)	2.0 in. (5.1 cm)	3.0 in. (7.6 cm)
C = Length	4.0 in. (10.1 cm)	4.0 in. (10.1 cm)	6.0 in. (15.2 cm)

*Height includes 0.7 in. (1.8 cm) for the computer electronics.

Pressure Rating (Aluminum):		300 psi (21 bar)
Operating Temperature Range:		-40° F to 250° F (-40° C to 121° C)
with Safe Area Only Display:		0° F to 140° F (-18° C to 60° C)
with Intrinsically Safe Display:		0° F to 129° F (-18° C to 54° C)
Typical K-Factor:	A025	2,200 PPG (581 Pulses/L)
	A100	730 PPG (193 Pulses/L)
	A200	72 PPG (19 Pulses/L)
Frequency Range:	A025	11-110 Hz @ 0.3-3 GPM (1-11 L/min)
	A100	36.5-608.3 Hz @ 3-50 GPM (11-190 L/min)
	A200	36-360 Hz @ 30-300 GPM (114-1135 L/min)
Recommended Strainer Size:	A025	55 mesh (275 µm)
	A100	28 mesh (700 µm)
	A200	28 mesh (700 µm)
Wetted Materials (Aluminum):	Housing:	Aluminum
	Bearings:	Ceramic (96% Alumina)
	Shaft:	Tungsten Carbide
	Rotor:	Nylon
	Rings:	316 Stainless Steel
Calibration Report:	Comes standard with A1 Series meters.	
	N.I.S.T. – Certification available.	

ACCESSORIES

Part No.	Description
113275-10	FM Approved Remote Kit Assembly [†]
113435-10	Conditioned Signal Output Module
125260-02	90° Display Adapter Kit
120077-01	FM Approved Sensor Kit [†]
120077-02	ATEX Approved Sensor Kit [†]
113524-01	Connector Kit for FM or ATEX Approved Sensor [†]
125060-10	Pulse Out, External Power, Scaled Pulse Module
125100-10	4-20 mA Module

[†]Does not make Non-FM or Non-ATEX Approved meters FM or ATEX Approved.



A1 SERIES FLOWMETERS, NYLON OPTION

FLOMEC® A1 Series Meters are designed as self-contained, battery powered units. Select the A1 Series when you need an accurate meter for water or non-aggressive chemical applications.

- Available in Nylon
- Nylon meter for use in water or non-aggressive chemical applications

FEATURES / BENEFITS

- Unique package combines Turbine and LCD into a self-contained, compact, economical meter
- Local Display Computer features: 2 Non-Volatile Totals (Batch Total = Resettable, Total = Non-resettable) and Rate of Flow
- Output capabilities available to communicate with process control equipment
- Lightweight, compact design allows for easy installation
- AAA Alkaline battery life: 2 years
- 12 selectable engineering units (gallons or liters are standard defaults)
- Factory calibration

APPLICATIONS

- Plant Process Water
- Batching / Blending
- Water / Non-Aggressive Chemicals
- Ag Chemicals
- Solvents / Glycol
- Chemical Feed Lines



PRODUCT CONFIGURATION

1 PRODUCT IDENTIFIER:

A1 = Electronic Digital Meter

2 ELECTRONIC CHOICE:

Computer Display, Meter Mounted

Q9 = Q9 2-Button Computer

*Computer Display & Module, Meter Mounted**

P9 = Q9 2-Button Computer w/Pulse Out Module, includes External Power and 10 ft. of Cable

42 = Q9 2-Button Computer w/4-20mA Module and 10 ft. of Cable

*Module, Meter Mounted (No Display)**

PO = Pulse Out (Unscaled) Conditioned Signal Module w/Cable

Retrofit Computer Kit (Display Only)

R9 = Q9 2-Button Computer Retrofit Kit (Replaces Q9 Display)

No Electronics - Turbine Only

XX = No Electronics - Turbine Only

**All Electronics Approvals Void*

3 CALIBRATION:

GM = Factory Default Calibration in Gallons

LM = Factory Default Calibration in Liters

XX = No Computer

4 TURBINE SIZE:

N025 = Nylon - Low Flow

N100 = Nylon - 1 inch

X### = No Turbine**

***When ordering Display Only, the ### should be the turbine size.*

5 FITTING TYPE:

N = NPT (Female)

I = ISO (Female) BSPT

X = No Turbine

6 PACKAGING:

With FM, ATEX & IEC Approval for HAZARDOUS AREA

A1 = Standard or Low Flow, 1 inch (w/Q9 & R9 Electronics Choice)

A2 = Standard, 2 inch (w/Q9 & R9 Electronics Choice)

B1 = Standard or Low Flow, 1 inch Turbine Only

B3 = Display Only

Non-Approved Version - SAFE AREA ONLY

C2 = Low Flow and 1 inch Turbines (w/P9, 42, & PO Electronics Choice)

1 2 3 4 5 6
---->>>> A1 Q9 GM N100 N A1

APPROVALS[†]



IP65



[†]All A1 Series Q9 Displays have the CE, NEMA 4, and IP65 approval.

SPECIFICATIONS

Meter Sizes Available:	N025 (Low Flow), N100 (1 inch)		
Design Type:	N025	Paddlewheel	
	N100	Turbine	
Fitting Size / Fitting Type:	N025	1 inch / NPT, ISO ⁺ (Female)	
	N100	1 inch / NPT, ISO ⁺ (Female)	
Flow Range:	N025	0.3 - 3 GPM	1 - 11 L/min
	N100	3 - 50 GPM	11 - 190 L/min
Accuracy (% of Reading):	N025: Application Dependent ¹		
	N100: ± 1.5%		
Repeatability:	N025	± 1.0%	
	N100	± 0.2%	

^{*}ISO 7 Designation is RC.

¹Accuracy can vary up to ± 5% depending on installation and fluid type. Field calibration is recommended for best accuracy.

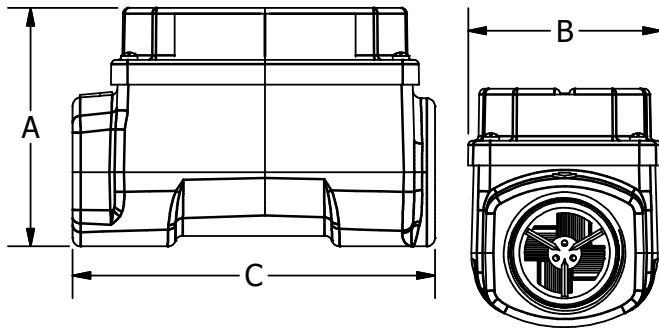

DIMENSIONS

	N025, 1 in. Low Flow	N100, 1 in.
A = Height*	2.5 in. (6.3 cm)	2.5 in. (6.3 cm)
B = Width	2.0 in. (5.1 cm)	2.0 in. (5.1 cm)
C = Length	4.0 in. (10.1 cm)	4.0 in. (10.1 cm)

*Height includes 0.7 in. (1.8 cm) for the computer electronics.

Pressure Rating (Nylon):	150 psi (10.3 bar)	
Operating Temperature Range:	-40° F to 250° F (-40° C to 121° C)	
	with Safe Area Only Display: 0° F to 140° F (-18° C to 60° C)	
	with Intrinsically Safe Display: 0° F to 129° F (-18° C to 54° C)	
Typical K-Factor:	N025	2200 PPG (581 Pulses/L)
	N100	730 PPG (193 Pulses/L)
Frequency Range:	N025	11-110 Hz @ 0.3-3 GPM (1-11 L/min)
	N100	36.5-608.3 Hz @ 3-50 GPM (11-190 L/min)
Recommended Strainer Size:	N025	55 mesh (275 µm)
	N100	28 mesh (700 µm)
Wetted Materials (Nylon):	Housing:	Nylon
	Bearings:	Ceramic (96% Alumina)
	Shaft:	Tungsten Carbide
	Rotor:	Nylon
	Rings:	316 Stainless Steel
Calibration Report:	Comes standard with A1 Series meters.	
	N.I.S.T. – Certification available.	

ACCESSORIES

Part No.	Description
113275-10	FM Approved Remote Kit Assembly [‡]
113435-10	Conditioned Signal Output Module
125260-02	90° Display Adapter Kit
120077-01	FM Approved Sensor Kit [‡]
120077-02	ATEX Approved Sensor Kit [‡]
113524-01	Connector Kit for FM or ATEX Approved Sensor [‡]
125060-10	Pulse Out, External Power, Scaled Pulse Module
125100-10	4-20 mA Module

[‡]Does not make Non-FM or Non-ATEX Approved meters FM or ATEX Approved.

Wichita · Sydney

GREAT PLAINS INDUSTRIES 

© 2022 Great Plains Industries, Inc. All Rights Reserved.

Service & Warranty: For technical assistance, warranty replacement or repair contact your FLOMEC® or GPI® distributor: In North or South America: 888-996-3837 / FLOMECmeters.com
Outside North or South America: +61 2 9540 4433 / FLOMECmeters.com

IND-1043-A1 Nylon Rev A 02/2022

TEMPCO sa www.tempco.be tempco@tempco.be tel : +32 4 248 92 60