

FCI ST100A Series Thermal Mass Flow Meters

Advanced Solutions for Process and Plant
Gas Flow Metering

Mass Flow, Temperature and Pressure



FCI ST100A SERIES

- Chemical
- Wastewater Treatment, Landfills
- Refineries
- Oil & Gas
- Mining
- Metals
- Manufacturing
- Cement, Stone, Brick, Glass
- Power Utilities
- Pulp & Paper
- Food & Beverage
- And more...

FCI FLUID COMPONENTS
INTERNATIONAL LLC

A PST BRAND



Model ST100A with -FP style flow element

Model ST100A readout

Model ST100AL in-line flow meter

ST100A Series Features

- Direct air and gas mass flow measuring
- Flow rate, total flow, temperature, pressure measurement
- No moving parts, lowest maintenance
- Most extensive and comprehensive global approvals for Ex installations
- Temperature service to 850 °F [454 °C]
- Rugged, industrial transmitter enclosure
- Graphic, multivariable LCD readout
- Integral and remote electronics versions
- Multi-gas calibrations
- Multiple analog outputs – 4-20 mA, pulse
- HART®, FOUNDATION™ Fieldbus, PROFIBUS PA, Modbus RS-485
- 3-point in-situ calibration self-check
- Dual-element systems
- Patented VeriCal™ In-Situ Calibration Verification System
- SIL compliant
- On-board data logger
- Sensor configurations to optimize application performance
- Extensive selection of process connections

ST100A Series – The Future of Gas Flow Metering

With FCI's ST100A Series, the science of process gas flow metering has never been so advanced or so future-ready!

ST100A Series thermal dispersion technology gas flow meters combine feature- and function-rich electronics with the industry's most advanced flow sensors to achieve a truly state-of-the-science flow metering solution for industrial processes and plant applications.

The ST100A Series transmitter is unsurpassed in meeting your current and future need for outputs, process information and communications. Every model includes three (3) 4-20 mA outputs, 0-1 kHz or 01-10 kHz frequency/pulse, HART, Modbus, and a USB port. Optionally, FOUNDATION Fieldbus or PROFIBUS PA can be added. That takes "never obsolete" to a whole new level.

Then there's ST100A's display/readout which brings new meaning to the term "process information." Simply, the ST100A's graphical display provides the most comprehensive information on process measurements and conditions of any thermal flow meter available (see page 7).

In the gas stream, ST100A flow elements and process connections ensure the best possible measurements and effective installation.

Then, consider other ST100A Series exclusives like dual-element averaging systems (see page 8), pressure measurement, and FCI's patented VeriCal option that provides dynamic wet calibration verification in-situ, without ever removing the instrument from the process (see page 11).

Dual-Technology Measuring Ensures Field Performance and Application Adaptability

FCI's ST100A Series is the only thermal dispersion flow meter to deploy both constant power (CP) and constant temperature (CT) thermal dispersion measuring techniques in the same instrument. For many applications the ST100A will be factory set in FCI's patented AST™ (Adaptive Sensing Technology) mode. AST™ is a hybrid that combines both CT and CP techniques in the same circuit. In AST™ operation the instrument measures in CT mode when in lower flow ranges or start-up conditions, and will transparently and seamlessly shift to CP mode at higher flow rates. The result is a best-of-both technology, achieving fast response, extended measuring range, and low power consumption. For other applications such as moist gases, pulsating flow streams and others, where a smoother, stable output is critical, the ST100A can also be set to measure in only CP mode. Since application conditions are not always completely known or understood at time of order, the ST100A's measuring mode can be user changed between AST™ or fixed CP in the field to adapt to actual application conditions.

Your smart investment in an ST100A Series flow meter is complete with FCI precision calibration. FCI's flow calibration facility, using equipment traceable to NIST and ISO/IEC 17025, is unmatched by any other thermal dispersion flow meter manufacturer. Your ST100A Series flow meter is custom calibrated to exacting process and fluid conditions, essential to providing the highest precision, longest lasting solution that meets its specifications and your specific application.

ST100A Series Model Summary

Model	ST Series				
	ST100A	ST100AL	ST102AA	ST110A	ST112AA
Basic Type	Insertion	In-Line	Insertion	Insertion	Insertion
Flow	✓	✓	✓	✓	✓
Temperature	✓	✓	✓	✓	✓
Dual-Element			✓		✓
VeriCal In-Situ Calibration Verification				✓	✓

Model	STP Series	
	STP100A	STP110A
Basic Type	Insertion	Insertion
Flow	✓	✓
Temperature	✓	✓
Pressure	✓	✓
Dual-Element		
VeriCal In-Situ Calibration Verification		✓

The ST100A Series is comprised of two core families—the “ST” and the “STP,” with seven total models. The ST family features instruments that measure both mass flow and temperature. The STP models are FCI exclusive thermal dispersion flow meters that additionally measure a third parameter—pressure.

Find your gas here?

FCI has provided thermal mass flow meter solutions for all of these and more . . .

Acetaldehyde	Ethyl Acrylate	Ketene	Phenol
Acetic Acid	Ethyl Alcohol	Krypton	Phosgene
Acetone	Ethyl Amine	Landfill Gas	Propadiene
Acetonitrile	Ethyl Benzene	M-Cresol	Propane
Acetyl Chloride	Ethyl Bromide	Mercury	Propanol
Air	Ethyl Chloride	Methane	Propyl Chloride
Allyl Chloride	Ethyl Fluoride	Methanol	Propylene
Ammonia	Ethyl Mercaptan	Methyl Acetate	Propylene Oxide
Aniline	Ethylene	Methyl Alcohol	Propyne
Argon	Ethylene Dichloride	Methyl Amine	P-Xylene
Benzene	Ethylene Oxide	Methyl Butane	R-11
Bio-Gas	Flare Gas	Methyl Fluoride	R-12
Boron Trifluoride	Fluorine	Methyl Formate	R-13
Bromine	Fluorobenzene	Methyl Hexane	R-13B1
Bromobenzene	Fluoroform	Methyl Hydrazine	R-14
Butadiene	Freon-11	Methyl	R-21
Butene	Freon-12	Mercaptan	R-22
Butylene Oxide	Freon-13	Methyl Octane	R-23
Butyne	Freon-14	Methyl Pentane	R-112
Carbon Dioxide	Freon-21	Methylal	R-113
Carbon Disulfide	Freon-22	Methylene Chloride	R-114
Carbon Monoxide	Freon-23	Morpholine	R-114B2
Carbon Tetrachloride	Furan	M-Xylene	R-115
Carbonyl Sulfide	Halon	Naphthalene	R-116
Chlorine	Helium	Natural Gas	R-134A
Chlorobenzene	Heptene	N-Butane	R-142B
Chloroethane	Hexanol	N-Butane	R-152A
Chloroform	Hexene	N-Butanol	R-216
Chloromethane	Hydrazine	N-Butyl Alcohol	R-500
Chloroprene	Hydrogen	N-Decane	R-502
Cis-2-Butene	Hydrogen Bromide	N-Dodecane	R-503
Cis-2-Hexene	Hydrogen Chloride	Neon	R-504
Compressed Air	Hydrogen Cyanide	Neopentane	R-C318
Cumene	Hydrogen Deuteride	N-Heptane	Radon
Cyanogen	Hydrogen Fluoride	N-Hexane	Silane
Cyclobutane	Hydrogen Iodide	N-Hexane	Silicon Tetrachloride
Cyclohexane	Hydrogen Peroxide	Nitric Oxide	Styrene
Cyclooctane	Hydrogen Sulfide	Nitrogen	Sulfur Dioxide
Cyclopentane	Iodine	Nitrogen Dioxide	Sulfur Hexafluoride
Cyclopropane	Isobutane	Nitromethane	Sulfur Trioxide
Decene	Isobutene	Nitrous Oxide	Superheated Thiophene
Deuterium	Isobutyl Alcohol	N-Nonane	Titanium Tetrachloride
Deuterium Oxide	Isopropane	N-Octane	Toluene
Diethyl Amine	Isopentane	Nonene	Trans-2-Butene
Diethyl Ether	Isopentane	N-Pentane	Trimethyl Amine
Diethyl Ketone	Isopropyl Alcohol	N-Propanol	Triptane
Digester Gas	Isopropyl Amine	N-Undecane	Uranium Hexafluoride
Dimethyl Ether	Isoheptane	Octene	Vinyl Acetate
Dimethyl Propane	Isohexane	Oxygen	Vinyl Chloride
Dimethyl Sulfide	Isooctane	O-Xylene	Vinyl Fluoride
Ethane	Isopentane	Ozone	Vinyl Formate
Ethanol	Isoprene	Pentanol	
Ethyl Acetate	Isopropyl Alcohol	Pentene	

Inputs, Outputs and Bus Communications for Today and Tomorrow

ST100A Series' extensive and comprehensive offering of outputs is your assurance of compatibility with your process control system for the long term. Whether your network is analog based or bus comm based, there is a compatible solution with ST100A. And, if your plant has ever considered changing or upgrading system communications in the future, the ST100A Series is ready to change with you.

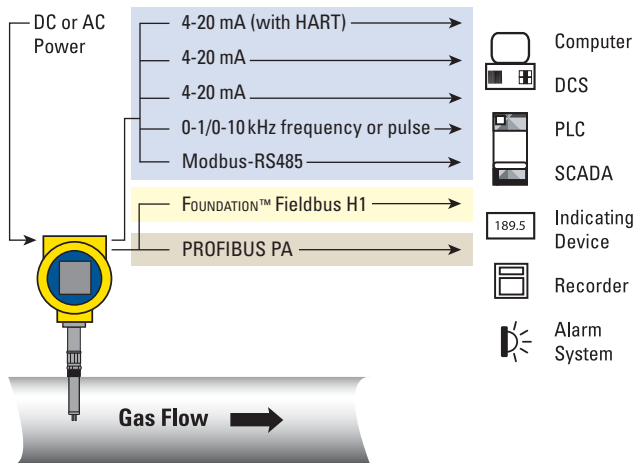

Standard Outputs Bundle

- Three 4-20mA
- Pulse/Frequency, 0-1kHz or 0-10kHz
- HART v7 I/O
- Modbus RTU RS485

Comprehensive, scalable, and flexible describe the ST100A Series' standard outputs bundle. It includes triple 4-20mA analog outputs that are user scalable and assignable to flow rate, temperature, and with STP models, pressure. These 4-20mA outputs are isolated and comply with NAMUR NE43 fault indication guidelines. For use with external flow computers or flow totalizers, also included, is a frequency/pulse output of either 0-1kHz or 0-10kHz. To connect with HART field programmer devices or HART-based digital control networks, all ST100A Series, also include certified and registered HART, version 7, I/O communications. The compatible device driver (DD file) has also been verified and certified by HART and is supplied with the instrument, and updates downloadable from the FCI website. Further, too interface with PLC's and other Modbus-based devices, all ST100A series flow meters include a Modbus RS485 interface.

Optional Digital Bus Communications

- Foundation Fieldbus
- Profibus-PA

In addition to the standard outputs bundle described above, a ST100A Series' flow meter can also include either Foundation Fieldbus* or Profibus-PA digital communications. These digital communications are full I/O that provide all measurement values (flow rate, totalized flow, temperature, and with STP models, pressure), along with their assigned engineering units over the bus. All instrument diagnostics and service information are also continuously accessible over these bus comms. Device drivers and interface software, either EDD or DTM type, for easy, seamless integration with process control systems and PC-based frame applications such as PACTware, are always supplied as well as are downloadable from FCI's website. As software extensions, such as PDM or FDT, are developed, they, too, are available for download by ST100A series users via FCI's website.

** ST100A Series with FOUNDATION™ Fieldbus communications is a certified and registered device with FieldComm Group™. Registered features include alarms and events, function block linking, trending, multi-bit alert reporting and field diagnostics. The ST100A was one of the first two devices to be compliant and certified with advanced field diagnostics. Manufacturer ID (HEX) 01FC49.*

ST100A Series with HART® communications is a certified and registered device with FieldComm Group, registration number L2-06-1000-168. Manufacturer ID (HEX) 00A6.



www.hartcomm.org



www.profibus.com



www.fieldbus.org



www.fdtgroup.org

Digital I/O Ports

All ST100A Series models include a USB port for connection to a laptop or other computer for all user set-up programming, field enactable device changes and servicing diagnostics. Also provided standard is an Ethernet 10/100 network port designed to facilitate remote access by FCI service personnel to perform service and diagnostics. Connection to both USB and Ethernet ports are conveniently accessed at the rear wiring panel.

FCI's comprehensive PC software tool "Configurator" for instrument set-up, stored data retrieval, service and trouble-shooting diagnostics is also included with every ST100A model. Updates to Configurator can be downloaded from the FCI website.

Digital Display / Readout

The ST100A Series' optional digital readout provides a best-in-class information suite, backlighted LCD and four (4) optical touch buttons. The display backlight has a unique proximity detector that illuminates it only when a person approaches, or can be set to "always on." The display and button functions can be rotated electronically, via the buttons, in 90° increments to optimize display viewing and button activations.

The display buttons provide convenient, ready access to all instrument set-up and programming, as well as diagnostics and

troubleshooting. (In the blind unit, these functions must be performed through the USB port or bus communications.) These buttons are activated through the front panel glass. There is no need to open the enclosure or declassify a hazardous area to perform functions. An atypical button sequence is required for button activation which prevents accidental or unauthorized access to the menus.

The display provides readouts of the process variables and service diagnostics. The normal process measuring mode screen is the most comprehensive of any thermal dispersion flow meter available.

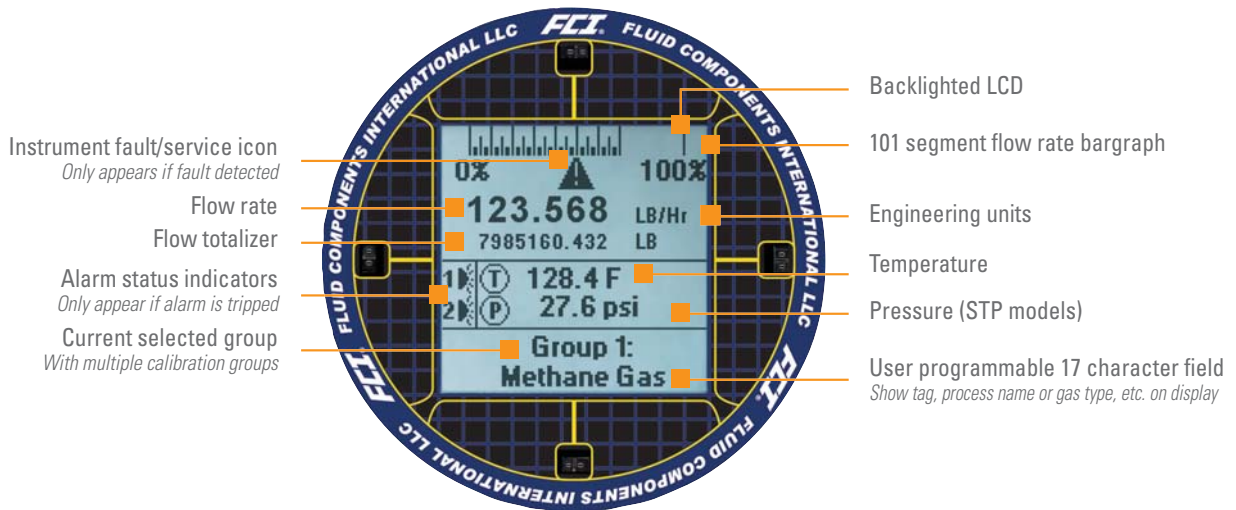

Four (4) optical touch buttons for programming and display selections

- Activated through front panel window; no need to open enclosure
- Protected from accidental or unwanted activation

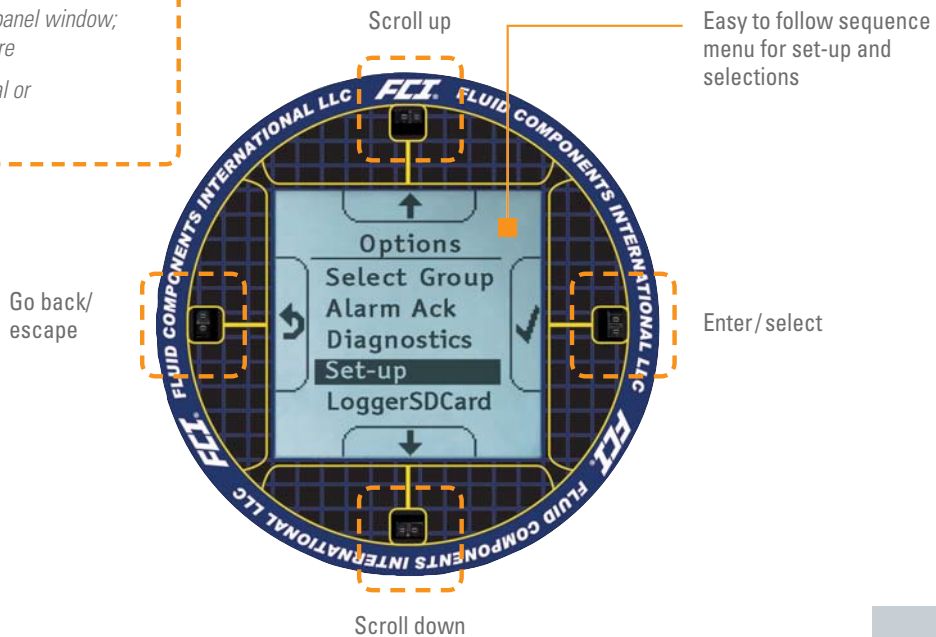

Sensors Optimized to Meet the Application



"FPC" Style Element



"FP" Style Element



"S" Style Element



"WG" Style Wet Gas Element

High quality thermal mass flow measurement begins with the sensor element in the flow stream. Only FCI combines six decades of field experience with extensive R&D and performance validation utilizing an on-premise flow laboratory with more than 19 flow stands. FCI is the leader in thermal mass flow sensor innovation, reducing the size of instruments, accelerating response time and improving overall operation in applications with dramatic temperature swings. Further, ST100A Series flow elements are all-welded to ensure maximum strength, durability and leak prevention, and are offered standard in either 316L stainless steel or Hastelloy-C276.

The "WG" is a new, FCI exclusive design specifically for use in wet gas or rain-down applications. This truly unique, mechanical design shunts moisture, condensation and water droplets away from the sensors, allowing the sensors to accurately measure the gas flow without being disrupted by water hitting the sensors. This "WG" sensor can be ordered for use with entrained moisture (moisture flow is same direction with gas) or for rain (incoming moisture in opposite direction from gas flow).

The table below provides a summary of conditions and characteristics to consider in selecting a flow element style.

ST100A Series Flow Element Selection

Flow Element	-FPC	-FP	-S	-WG
Available with insertion type	✓	✓	✓	✓
Available with in-line type (ST100AL)		✓*	✓	
Conditions or Characteristics				
All clean gases	■	□	□	⊘
Air / compressed air	■	□	□	⊘
Slightly dirty gases	□	■	□	⊘
Damp / moist gases	□	□	■	■
Very dirty gases	⊘	□	■	⊘
Wet gases	⊘	⊘	⊘	■
Open vertical stack or pipe with gas flow coming up, rain/moisture coming down	⊘	⊘	⊘	■
Erosive	⊘	⊘	■	⊘
Corrosive	⊘	⊘	■	⊘
Particulates in flow stream	⊘	□	■	⊘
Pulsing	■	⊘	■	⊘
Fastest response time	■	■	□	⊘
Dynamic temperature swings	■	■	⊘	⊘
Rapid or erratic changes in flow requiring smoothed response and output	⊘	⊘	■	⊘
Less-than-ideal straight run (without Vortab® flow conditioning)	■	⊘	⊘	⊘
Frequent cleaning required	⊘	□	■	⊘

■ = Excellent performance, preferred solution

□ = Good performance, acceptable solution

⊘ = Not recommended

* = Unshrouded as sensor head protected by spool-piece

Extensive Selection of Process Connections

An unmatched selection of process connection choices assures a match for any installation requirements.

Insertion flow meters – For most applications an adjustable "U" length (insertion depth) configured with compression fittings offers the most installation flexibility. Adjustable elements are available in 6 inch [152 mm], 12 inch [305 mm], 21 inch [533 mm], 36 inch [914 mm], and 60 inch [1524 mm] lengths. All adjustable "U" elements include permanent, laser-etched depth gauge markings, in both inches and millimeters, to ensure accurate insertion depth within the installation. Male NPT compression fittings are available in either 3/4 inch or 1 inch, with Teflon or metal ferrules, or with a tapped and threaded ANSI or DIN flange. Fixed length elements made to your specifications with a fixed threaded fitting or a welded ANSI or DIN flange are also available for all ST100A Series models.

For hot tap installations, retractable packing glands with a choice of pressure rating and packing material are available for all ST100A insertion flow meter models. Pressure service ratings of either 50 psi [3,4 bar] or 500 psi [34 bar] are standard with higher ratings available on special request. To ensure compatibility with the process fluid and integrity of the installation, packing material is selectable as either graphite or Teflon¹.

In-line flow meter (Model ST100AL) – The spool-piece flow body length is nine times its nominal diameter, and can be fabricated as required with male NPT, female NPT, ANSI flange or DIN flange and butt weld prepared process connections.

¹ Teflon packing material may be required for certain process media such as ozone, chlorine or bromine; consult FCI's AVAL program for recommendation

² Chromium carbide coating also available; contact FCI



Adjustable "U" Length with Compression Fitting



Tapped and threaded ANSI or DIN Flange



Low Pressure Packing Gland with Ball Valve (top) and Medium Pressure Packing Gland with Ball Valve (right)

ST100A Series Insertion Flow Meters

Model	ST100A	ST102AA	ST110A	ST112AA	STP100A	STP110A
Flow Element						
FPC Sensor Style	✓	✓				
FP Sensor Style	✓	✓	✓	✓	✓	✓
S Sensor Style	✓	✓				
WG Wet Gas Sensor Style	✓	✓			✓	
316L SS Sensor	✓	✓	✓	✓	✓	✓
Hastelloy-C276 Sensor	✓	✓				
All Welded Element	✓	✓	✓	✓	✓	✓
Temperature Service and Measuring Range <i>All ST models -40 °F [-40 °C] to:</i>	≤ 350 °F [177 °C] ≤ 500 °F [260 °C] ≤ 850 °F [454 °C]	≤ 350 °F [177 °C] ≤ 500 °F [260 °C] ≤ 850 °F [454 °C]	≤ 350 °F [177 °C] ≤ 500 °F [260 °C]	≤ 350 °F [177 °C] ≤ 500 °F [260 °C]	Standard: 32 °F to 176 °F [0 °C to 80 °C] Ex Rated: -22 °F to 212 °F [-30 °C to 100 °C] <i>Limited by pressure transducer, contact FCI for special order, higher temp. service</i>	
Pressure Measurement Ranges					■ 0-50 psig [3,4 bar (g)] ■ 0-160 psig [11 bar (g)]	■ 0-500 psig [34 bar (g)] ■ 0-1000 psig [70 bar (g)]
Process Connections						
Compression Fittings with variable "U" length up to 6", 12", 21", 36" or 60" [152 mm, 305 mm, 533 mm, 914 mm or 1524 mm]						
3/4" MNPT	✓	✓				
1" MNPT	✓	✓				
Flange, Tapped and Threaded for 3/4" NPT Compression Fitting	✓	✓				
Retractable Packing Glands* with variable "U" length up to 6", 12", 21", 36" or 60" [152 mm, 305 mm, 533 mm, 914 mm or 1524 mm]					<i>* Contact FCI for pressures > 500 psi [34 bar (g)]</i>	
Low Pressure ≤ 50 psi [3,4 bar (g)]	✓	✓	✓	✓	✓	✓
Medium Pressure ≤ 500 psi [34 bar (g)]	✓	✓	✓	✓	✓	✓
Fixed specify "U" length up to 60" [1524 mm] maximum						
1" MNPT	✓	✓	✓	✓	✓	✓
Flanged	✓	✓	✓	✓	✓	✓

ST100AL In-Line For Line Sizes 1", 1 1/2", 2" [25 mm, 40 mm, 51 mm]

Model	ST100AL
Flow Element	
FP Sensor Style	✓
S Sensor Style	✓
316L SS Sensor	✓
Hastelloy-C276 Sensor	✓
All Welded Element	✓
Temperature Service	≤ 257 °F [125 °C]
Process Connections	
1" Tubing	✓
1" Pipe	✓
1 1/2" Pipe	✓
2" Pipe	✓
NPT (Male)	✓
NPT (Female)	✓
Flanged	✓
Butt Weld	✓



Single-point insertion flow meter for pipe sizes 2 1/2" [64 mm] and larger. Calibration ranges from 0.25 SFPS to 1000 SFPS [0,07 NMPS to 305 NMPS].

– Models ST100A, STP100A



In-line spool-piece flow meter for use in line sizes 1", 1 1/2", and 2" [DIN25, DIN40, and DIN50]. Typical calibration range is from 0.006 SCFM to 838 SCFM [0,01 NCMH to 1425 NCMH].

– Model ST100AL



Dual-element insertion flow meters with averaging mode for improved accuracy and repeatability in line sizes ≥ 12" [305 mm].

– Models ST102AA, ST112AA



VeriCal™ In-Situ Calibration models are insertion flow meters with the FCI exclusive VeriCal in-situ calibration verification system.

– Models ST110A, STP110A, ST112AA

Two Sensor Averaging System

Applications involving line sizes 12 inches [305 mm] or greater can realize improved installation accuracy and repeatability by averaging the flow rates of two elements. Distorted, swirling and non-repeatable flow profiles can result in decreased accuracy of single point meters. In many cases, it is impractical or impossible to provide the required straight-run for a fully developed flow profile in large lines.

Models ST102AA and ST112AA overcome these flow profile concerns with a simple, economical "dual-element averaging system." The transmitter electronics will average the input from two independent flow elements into a single output. Each flow element can be independently configured for insertion length and process connection to allow installation flexibility. One flow element can be integral with the flow transmitter, or both can be configured as remote to accommodate easy access to terminal blocks and the optional digital display/optical four button interface. The flow transmitter also provides independent information for each flow element, saving time when performing service checks.

To help determine if your application will benefit from using a dual-element averaging system, contact your local representative or visit FCI online to utilize AVAL, FCI's proprietary evaluation software.

With any two-element system, one element is always remote mounted while the other may be integrally mounted or remote mounted from the transmitter.

With Integral Configuration

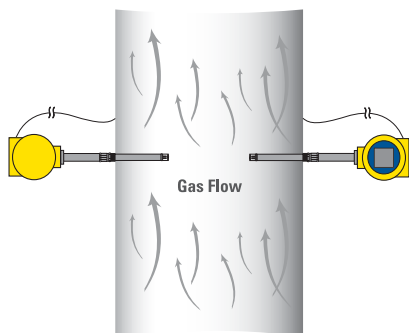

With Remote Transmitter

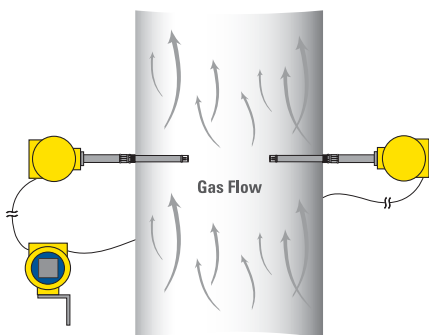

Up to Five Unique Calibrations

While a single calibration is sufficient for many operations, the ST100A Series can provide up to five (5) unique calibration groups. Depending on your application need, this feature can provide significant cost and time savings. Some examples include:

Broaden measuring range – Extend the turndown ratio up to 1000:1 or have different ranges for the same gas to maximize accuracy and resolution under changing conditions. This is particularly beneficial with flares, which can require both a low flow range for normal operation and leak detection, and also a very high flow range for upset conditions. Multiple calibration group settings saves on the cost of using multiple flow meters.

Different mixtures of same gases – Embed calibrations to optimize flow measurement accuracy in dynamic or seasonally affected processes (e.g. Digester Gas Group 1 is 65% CH₄, 35% CO₂; Group 2 is 62% CH₄, 38% CO₂).

Different gases – Portable or temporary installations for multiple applications, or to reduce spare parts inventory in plants with multiple installations and applications. Multiple gases, such as dual fuel sources (e.g. natural gas and propane).

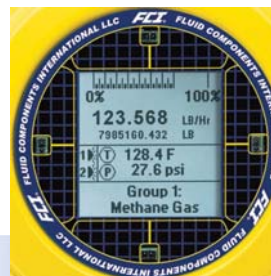

Add Pressure Measurement with “STP” Models

The “STP” models are the only thermal dispersion gas mass flow meters available featuring pressure measurement to create a triple function solution (flow + temperature + pressure) in a single tap point insertion instrument—an industry first and FCI exclusive feature.

A precision strain gauge pressure transducer is built into the STP probe assembly and integrated into the transmitter inputs and outputs. The transducer, connections and wiring assembly are enclosed within a compact, protective aluminum housing and incorporated into the flow element assembly. Four pressure ranges are available: 50, 160, 500 and 1000 psig [3,4; 11; 34 and 70 bar(g)] to maximize resolution and accuracy for your application. Pressure transducers are available in both Ex and non-Ex rated types.

In addition to the labor savings over installing and running power to multiple sensors, bus communication installation reduces bus wiring, nodes and interfacing because all three measurements are provided over a single bus connection. Analog outputs and alarm values are also user assignable to pressure measurement as required by your application. In STP models with the optional graphical/digital display, the pressure measurement value is added and continuously displayed.

Model STP100A: Single-point insertion flow element with flow, temperature and pressure

Model STP110A: Single-point insertion flow element with flow, temperature and pressure and VeriCal



Shown with optional low pressure packing gland

Model STP100A

Model STP110A

On-Board Data Logger

ST100A Series electronics include a user selectable and programmable data logging feature. Readings are stored to a removable, internal, board-mounted, micro-SD card (micro secure digital memory card). The supplied micro-SD card has a 8GB capacity capable of storing approximately 80 million readings. Recording time base is user selectable with maximum rate of 1 reading per second. The logging feature is selectable via the front panel menu or via the serial port and configuration software tools. Readings are stored in ASCII, comma separated format for easy uploading to spreadsheets such as MS-Excel.

Full Instrument Agency Approvals

ST100A Series meters are agency approved for hazardous environment installations. FCI products undergo rigorous agency testing and obtain their approvals on the entire instrument, not just the enclosure. This highest level of agency certification is your evidence of FCI’s integrity. This ensures that every FCI instrument meets the intended safety requirements of your installation.

- FM, FMc: Class I, Division 1, Explosion proof, Groups B, C, D
 Class II/III, Division 1, Dust ignition proof, Groups E, F, G
 Class I, Division 2, Nonincendive, Groups A, B, C, D
 Class II, Division 2, Nonincendive, Groups E, F, G
 Class III, Division 1, 2, Dust ignition proof, indoor/outdoor
 Hazardous (classified) locations
 Type 4X/ IP67; Per NEC 500
- ATEX/UKEX: II 2 G EX db IIC T6...T1 Gb Ta = -40°C to +60°C; IP66/67
 II 2 D Ex tb IIIC T85°C...T450°C Db Ta = -40°C to +60°C;
 IP66/67 *
- IECEX: Ex db IIC T6...T1 Gb Ta = -40°C to +60°C; IP66/67
 Ex tb IIIC T85°C...T450°C Db Ta = -40°C to +60°C;
 IP66/67 *

Other Compliances: CE Marking, UKCA, CPA, NEPSI, EAC/TR CU, CRN, EMSA EQM-Ex, pending Inmetro, PED, RoHS Compliant
 Probe complies with NEC & CEC code requirements of ANSI/ISA 12.27.01-2011 as a single seal device

SIL 1 compliant

* Available in standard and elevated T-Ratings; see specifications on page 13.

FCI continually obtains additional agency approvals; contact FCI for availability of other agency approvals



FCI's World Class Calibration Ensures Installed Accuracy

ST100A Series models are tested and calibrated to rigorous standards so that you get the instrument that does the job specified. To design and produce the highest quality flow instrumentation, FCI operates a world-class flow calibration laboratory with calibrations performed on more than 19 different flow stands, using equipment traceable to NIST (US National Institute of Standards and Technology), and ISO/IEC 17025 (International Standards for test lab quality systems).

To achieve the highest possible accuracy in ST100A Series, FCI utilizes these precision flow stands to flow actual gases and reference fluids matched to the temperature and process conditions of your application. Further utilizing the extensive flow laboratory capabilities, FCI has developed an all new, patented and scientifically engineered SpectraCal gas equivalency algorithm as an economical alternative to actual gas calibration.

Other suppliers are often limited only to air calibrations and rely on non-field tested or un-validated theoretical equivalencies for other gases and gas mixtures. This procedure can be inadequate and create measurement and output errors well outside published specifications. FCI calibration capabilities are unmatched in the industry, providing you with total confidence that your installation meets its published specifications and your application needs.

More than 19 NIST traceable precision flow stands to match fluids, process conditions, flow rates and line sizes specified in your application.



ST100A Series In-Situ Calibration Validation Self-Test

- **Simple to initiate, one minute test**
- **3-point check across span**
- **No need to retract or remove meter from the process**
- **Pre-set to run automatically and record to data logger**
- **View and record results**

A calibration self-test feature is standard with all ST100A Series flow meters. To save user time and expense, the self-test is performed in-situ – there is never a need for the ST100A to be removed or retracted from process piping or to suspend the processes operation.

This self-test feature initiates an electronic, three point calibration drift self-test. In the test mode, the ST100A automatically and sequentially substitutes three precision resistors into the measuring circuit and compares the resulting measurements against the same measurements at factory calibration. These three points represent low-range, mid-range and high-range points to provide a thorough check across the span of the flow range.

Unique to the FCI ST100A Series is that the self-test may be initiated in three ways by the user:

- 1) On demand from the ST100A flow meter's keypad – through-the-glass activation, no need to remove the lid (Figure 1).
- 2) On demand from a computer connected to the flow meter's USB port.
- 3) Automatically on pre-set day(s) and time(s), programmable.

The results of the self-tests provide the operator with an easy to understand PASS/FAIL message for each of the three test points, plus the digital reading of the actual base line values shown in comparison to the actual resulting test values. Results are displayed on the ST100A's digital display and/or the computer connected to the USB port. In the automatic preset mode, results can be stored on the ST100A on-board data logger for review at any time.

Figure 1. Front panel; all three check points show "P" (pass) and entire self-check "PASSED"



For more rigorous "wet" in-situ calibration verification, see FCI Model ST110 with VeriCal™ on page 11

VeriCal™ In-Situ Calibration Verification

Models ST110A, ST112AA, and STP110A

- **Validate performance on-site in minutes**
- **Save costs, no need to remove flow meter from process**
- **Comply with ISO and local regulations for periodic calibration verification**
- **Provides in-situ flow element cleaning**

Models ST110A, ST112AA, and STP110A include FCI's exclusive and patented VeriCal system. VeriCal provides you with the ability to perform periodic field validation and verification of the flow meter's measuring performance and calibration without extracting the flow meter from the pipe or process.

In gas flow processes with procedures or regulations requiring periodic calibration verification, an FCI flow meter configured with VeriCal provides the most convenient and lowest cost solution. Performing a verification with VeriCal also provides a secondary benefit of cleaning the flow element which helps ensure performance and reduce the need for routine maintenance.

The VeriCal option is comprised of three components:

- **VeriCal ready flow element** – This specially-constructed flow element includes a flow port at the sensors, internal tubing, sonic nozzle and precision orifice, a ball valve to select "normal" or "VeriCal" operation and a welded and sealed inlet check valve to prevent hazardous process gases from escaping. After the flow meter system has been precision calibrated in FCI's NIST traceable flow laboratory, the lab also performs an additional nitrogen calibration and obtains five (5) baseline measurement points across the flow range to which all field checks using the VeriCal system are compared. With each ST110A, ST112AA, or STP110A, FCI provides a second calibration curve and printed document showing the five baseline VeriCal flow readings for use by your field technicians. This VeriCal calibration curve is stored within one of the ST100A Series' five calibration groups. The VeriCal calibration is quickly and easily accessed and recalled from the first menu screen on the display.

- **VeriCal kit** with fixtures and fittings to meter and control a precise flow of nitrogen⁴ across the ST flow element. The VeriCal kit provides a specially designed 100 psig [6,9 bar(g)] pressure regulator and LCD digital pressure gauge packaged in a NEMA 4 (IP66) rated enclosure, and a 25 foot [7,6 m] air hose with quick disconnect fittings to connect the kit to the VeriCal ready flow element. The kit is fully portable or can be permanently mounted. The VeriCal kit, part number 020849-03, is ordered separately as a second line item. A single VeriCal kit can be used with and support any number of VeriCal-ready flow elements.

- **Nitrogen source** (user supplied) with a hose, regulated 125 psig to 150 psig [8,6 bar(g) to 10,3 bar(g)], either from an installed plant line or a portable supply tank. Typical test requires approximately 40 ft³ [1,1 m³] of nitrogen.

How It Works

With the VeriCal kit attached to the ST flow meter and the nitrogen source, a positive-pressure nitrogen injection is introduced⁴. With the ST flow element fully retracted from the actual flow stream and the ST set in the VeriCal Calibration group mode, the user adjusts the pressure at the VeriCal kit to inject small, controlled doses of nitrogen at specific pressures (prescribed on the FCI VeriCal calibration document). At each pressure point, flow readings are taken from the ST flow meter and compared to the respective baseline readings in the documentation provided by FCI. This procedure is performed at initial installation, then as often as desired.

Model ST110A: Single-point insertion flow meter configured with VeriCal

Model ST112AA: Dual-element flow meter; both elements configured with VeriCal

Model STP110A: Single-point flow meter with pressure measurement configured with VeriCal

P/N 020849-03: VeriCal kit

⁴ Other gases may be used; contact FCI for specific information

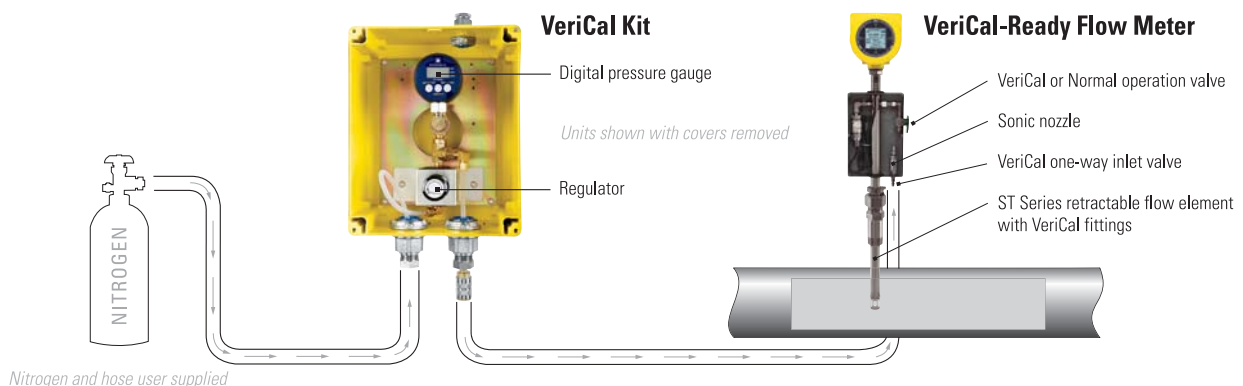

ST100A Series Features

Four conduit ports provide greatest signal integrity and separation for power input, analog output lines, digital I/O, and/or auxiliary input signals; choice of NPT or M20 threads

SIL 1 compliant

AC or DC power supply

Weather-proof, ruggedized, Ex rated enclosures

- Choices for local or remote mounting
- NEMA 4X, IP67
- Aluminum standard, stainless steel optional

Global agency approvals of entire instrument system for hazardous location installations:

FM, FMc, ATEX, IECEx, NEPSI, EAC (TRCU), UKEX, EMSA EQM-Ex

Multiple calibrations

- Up to five independent, separate calibrations
- Multiple gases or mixed gas compositions
- Same gas, different flow range to optimize accuracy and extend turndown up to 1000:1

Precision calibration and calibration choices

- Specific gas and application matched calibration using equipment traceable to NIST and ISO/IEC 17025

Extensive selection of process connections

- Simple, adjustable installation with threaded NPT connector
- Teflon or metal ferrule seals
- Fixed connections
- ANSI or DIN flanges
- Retractable assemblies

Stainless steel or Hastelloy-C276 wetted parts

Precision, wide-ranging platinum RTD sensors

Choice of four flow element styles to optimize application performance

- FPC style
- FP style (shown)
- S style
- WG wet gas style

Extensive analog and digital communications output choices

- Triple 4-20 mA with HART
- Modbus RS-485
- 0-1 kHz or 0-10 kHz frequency or pulse
- USB port
- FOUNDATION Fieldbus H1
- PROFIBUS PA

On-board data logger

3-point user-initiated calibration self-check

Four (4) optical touch buttons

- Proximity activation, no need to open enclosure
- Full instrument programmability
- Protected against unwanted activation

Comprehensive informational display

- Digital readout of all measured parameters; flow rate, total flow, temperature and pressure with engineering units
- Analog flow rate bar graph
- Alarm status indication
- Instrument fault indication
- User programmable 17 character field (example: display gas type, tag number or application/location)
- Display orientation rotates in 90° increments electronically
- Backlighted

Multi-function: measures mass flow rate and temperature; STP Series adds pressure measurement

Permanent laser-etched depth gauge markings; ensures accurate centering of adjustable-length elements

All welded sensor elements for maximum service life and leak-proofing

Exclusive equal mass sensors provide optimum performance in processes with wide temperature swings



Remote up to 1000' [300 m]

Optional stainless steel enclosure



ST100AL in-line style

Optional sun shield



ST100A with sun shield

ST100A Series Mass Flow Meter Specifications

Instrument

Measuring Capability

ST1XXA Models: Flow rate, total flow and temperature
STP1XXA Models: Flow rate, total flow, temperature and pressure

Basic Style

ST100A: Insertion, single-point
ST100AL: In-line (spool piece), single-point
ST102AA: Insertion, dual-element system
ST110A: Insertion, single-point with VeriCal™ capability
ST112AA: Insertion, dual-element system with VeriCal capability
STP100A: Insertion, single-point with pressure measurement
STP110A: Insertion, single-point with pressure measurement and VeriCal capability

Flow Measurement Range

Insertion Style: 0.25 SFPS to 1000 SFPS [0.07 NMPS to 305 NMPS]
ST100AL In-line: 0.0062 SCFM to 838 SCFM [0.01 NCMH to 1425 NCMH]
 – Air at standard conditions; 70 °F and 14.7 psia [0 °C and 1,01325 bar(a)]

Temperature Measurement Range

Up to 850 °F [454 °C] commensurate with element; *see Operating Temperature in Flow Element specification*

Pressure Measurement Range (STP Models)

Available Ranges:
 0 psig to 50 psig [0 bar(g) to 3.4 bar(g)]
 0 psig to 160 psig [0 bar(g) to 11 bar(g)]
 0 psig to 500 psig [0 bar(g) to 34 bar(g)]
 0 psig to 1000 psig [0 bar(g) to 70 bar(g)]

Media:

All gases that are compatible with the flow element material

Accuracy

Flow: Gas specific calibration: ±0.75% reading, ±0.5% full scale
Temperature: ±2 °F [±1.1 °C] (display only, flow rate must be greater than 5 AFPS [1.5 m/sec])
Pressure (STP Models): ±1.0% of span

Temperature Coefficient

With optional temperature compensation; valid from 10% to 100% of full scale calibration
Flow: Maximum ±0.015% of reading / °F up to 850 °F [±0.03% of reading / °C up to 454 °C]

Repeatability

Flow: ±0.5% reading
Temperature: ±1 °F [±1 °C] (flow rate must be greater than 5 AFPS [1.5 NMPS])
Pressure (STP Models): ≤0.1% of span

Turndown Ratio

Normally factory set and field adjustable from 2:1 to 100:1 within calibrated flow range; up to 1000:1 possible with factory evaluation of application

Temperature Compensation

Standard: ±30 °F [±16 °C]
Optional: ±100 °F [±55 °C]

Agency Approvals

FM, FMC: Class I, Division 1, Explosion proof, Groups B, C, D
 Class II/III, Division 1, Dust ignition proof, Groups E, F, G
 Class I, Division 2, Nonincendive, Groups A, B, C, D
 Class II, Division 2, Nonincendive, Groups E, F, G
 Class III, Division 1, 2, Dust ignition proof, indoor/outdoor
 Hazardous (Classified) locations
 Type 4X/IP67
 ATEX/UKEX: II 2 G Ex db IIC T6...T1 Gb Ta = -40°C to +60°C; IP66/67
 II 2 D Ex tb IIIC T85°C...T450°C Db Ta = -40°C to +60°C; IP66/67*
 IECEx: Ex db IIC T6...T1 Gb Ta = -40°C to +60°C; IP66/67
 Ex tb IIIC T85°C...T450°C Db Ta = -40°C to +60°C; IP66/67*
 Other: EAC (TRCU), CRN, UKEX, EMSA EQM-Ex, CE Marking, NEPSI, PED, RoHS Compliant, UKCA, *Pending: Inmetro*, Probe Complies with Canadian Electrical code requirements of ANSI/ISA 12.27.01-2011 as a single seal device

*T-Rating (Probes)	Process Temperature Range	
	Standard	Optional Elevated**
	Agency approval ordering Codes ATEX = Code 3, IECEx = Code 4	Agency approval ordering Codes ATEX = Code C, IECEx = Code D
T4/T135°C	-40°C to +65°C	-40°C to +89°C
T3/T200°C	-40°C to +115°C	-40°C to +154°C
T2/T300°C	-40°C to +177°C	-40°C to +254°C
T1/T450°C	-40°C to +365°C	-40°C to +404°C

** Instrument will be fixed in AST measuring mode, and is not field-changeable into CP mode.

SIL: SIL 1 compliant

SFF %

	AC Powered	DC Powered
Single element types	79.8%	79.9%
Dual element types	88.9%	88.9%

to NIST and ISO/IEC 17025

Flow Element

Material of Construction

All-welded 316L stainless steel; Hastelloy-C optional

Operating Pressure

ST100A, ST102AA, ST110A, ST112AA Insertion Style

Metal ferrule: 1000 psig [70 bar(g)]
 Teflon ferrule: 150 psig [10 bar(g)] (200 °F [93 °C] maximum)
 Fixed connection NPT: 1000 psig [70 bar(g)]
 Fixed connection flanged: per flange rating

STP Models *See pressure sensor specifications*

Same as ST type above or per pressure sensor specification, whichever is lower

Model ST100AL In-line style

Tubing		Sch 40 Pipe		Sch 80 Pipe	
Psig	Bar(g)	Psig	Bar(g)	Psig	Bar(g)

F Style Sensor

1"	2400	165	2500	172	3000	207
1 1/2"			1750	121	2500*	172*
2"			1500	103	2250*	155*

S Style Sensor

1"	2400	165	2500	172	2500	172
1 1/2"			1750	121	2500*	172*
2"			1500	103	2250*	155*

3/4" pipe also available by special order

Operating Temperature (Process)

ST100A, ST102AA Insertion Style

All Flow Elements (FPC, FP and S):
 -40 °F to 350 °F [-40 °C to 177 °C]
 -40 °F to 500 °F [-40 °C to 260 °C]
 -40 °F to 850 °F [-40 °C to 454 °C]
With Wet Gas (WG) sensor -40 °F to 350 °F [-40 °C to 177 °C]

ST110A, ST112AA Insertion Style

FP Style Flow Element:
 -40 °F to 350 °F [-40 °C to 177 °C]
 -40 °F to 500 °F [-40 °C to 260 °C]

STP Series Insertion Style

FP Style Flow Element:
 Standard: 32 °F to 176 °F [0 °C to 80 °C]
 Ex Rated: -22 °F to 212 °F [-30 °C to 100 °C]

Limited by pressure transducer; contact FCI for special order, higher temperature service

ST100AL In-line Style

FP and S Style Flow Element:
 -40 °F to 257 °F [-40 °C to 125 °C]

Process Connection

Compression Fittings *Models ST100A and ST102AA only*

3/4" or 1" male NPT, stainless steel with adjustable Teflon ferrule or metal ferrule; or flanged tapped and threaded for 3/4" fitting, ANSI or DIN flanges

Compression fittings not available with 850 °F [454 °C] temperature versions of ST100A or ST102AA

Retractable Packing Glands

Low pressure 50 psig [3.5 bar(g)] or medium pressure 500 psig [34 bar(g)] with graphite or Teflon packing material; 1 1/4" male NPT or ANSI or DIN flange

Teflon packing required when process media is ozone, chlorine or bromine; remote mount required when medium pressure packing gland is required

Fixed Fittings/All Welded

1" male NPT or ANSI or DIN flange

Insertion Length

Field adjustable lengths:

1" to 6" [25 mm to 152 mm]
 1" to 12" [25 mm to 305 mm]
 1" to 21" [25 mm to 533 mm]
 1" to 36" [25 mm to 914 mm]
 1" to 60" [25 mm to 1524 mm]

Fixed lengths from 2.6" to 60" [66 mm to 1524 mm]

ST100AL In-line Flow Tube

Flow element is welded to an in-line flow tube, calibrated and supplied as a spool-

ST100A Series specifications continued on next page

ST100A Specifications Cont'd

piece; options include low flow injection tubes and built-in Vortab flow conditioners for optimum low flow rangeability and performance

Size: 1" diameter tubing; 1", 1 1/2" or 2" schedule 40 pipe

Length: 9 nominal diameters

Process Connections: Female NPT, male NPT, ANSI or DIN flanges, or butt weld prepared

Option: Flanges sized for flow tube

- **Remote Transmitter Configurations:** Transmitter may be mounted remotely from flow element using interconnecting cable (up to 1000' [300 m]); remote configuration required with medium pressure packing gland process connection
- **STP Models: Specifications on Pressure Sensor**

Standard Sensor	PSI	Bar	PSI	Bar	PSI	Bar	PSI	Bar
Pressure range	50	3,4	160	11	500	34	1000	70
Over pressure safety	100	7	290	20	1000	70	1740	120
Burst pressure	250	17,24	500	34	2500	172	7975	550
Wetted Materials:	316L		316L		316L		316L	
Connection	PH 13-8 SS		316L		316L		316L	
Pressure Sensor								

Ex Rated Sensor	PSI	Bar	PSI	Bar	PSI	Bar	PSI	Bar
Pressure range	50	3,4	160	11	500	34	1000	70
Over pressure safety	240	16,55	1160	80	1160	80	1740	120
Burst pressure	290	20	1390	95,84	5800	400	7970	549,5
Wetted Materials:	Stainless steel		Stainless steel		Stainless steel		Stainless steel	
Connection	Stainless steel		Stainless steel		SS and Elgiloy		Stainless steel	
Pressure Sensor	Stainless steel		Stainless steel		SS and Elgiloy		SS and Elgiloy	

Flow Transmitter/Electronics

Operating Temperature:

Single element models: -40 °F to 150 °F [-40 °C to 65 °C]

Dual element models: *ST102AA, ST112AA*,
-40 °F to 120 °F [-40 °C to 49 °C]

Input Power

AC: 85 Vac to 265 Vac, 50 Hz to 60 Hz;

Single element: 10 watt; dual element: 13.1 watt maximum

DC: 24 Vdc ± 20%;

Single element: 9.6 watt; dual element: 13.2 watt maximum

Outputs and Communications

Standard: Three (3) 4-20 mA³ analog, 0-1 kHz or 0-10 kHz pulse/frequency, HART⁴, Modbus RS-485⁴, and USB

4-20 mA outputs are user assignable to flow rate or temperature; outputs are user programmable to full flow range or subsets of full flow range

HART: Version 7; Fieldcomm Group certified and registered;
DD file included

Modbus: RS485 (in accordance with EIA/TIA-485 standard)

Modbus device type: Slave

Address range: 0-255

Supported function codes: 03,04

Supported baud rate: 9600,19200

Transmission mode: RTU and ASCII; standard MS (16 bit), standard LS (16 bit), Daniel extensions (32 bit)

Response time

(delay between polls): 50 ms or greater

Functions

Readings: Flow rate, temperature, totalized flow (single precision), flow engineering units, temperature engineering units

Other: Enable (activate) totalizer, reset totalizer

Optional: FOUNDATION Fieldbus H1⁴ or PROFIBUS PA⁴

³ 4-20 mA outputs are isolated and have fault indication per NAMUR NE43 guidelines, user selectable for high (>21.0 mA) or low (<3.6 mA)

⁴ Only one bus communication can be active at one time

Auxiliary Inputs

4-20 mA input channel used for FCI administered special configurations to

allow ST100A Series to accept inputs from external devices such as gas analyzers, gas composition or pressure sensors

Enclosures

Main Transmitter/Electronics

NEMA 4X, IP67; polyester powder coated aluminum or optional in stainless steel; 4 conduit ports threaded as 1/2" NPT or M20x1.5; 7.74" x 5.40" x 5.00" [196,6 mm x 137,2 mm x 127 mm]

Local Enclosure (Remote Configuration):

Model *ST100AL*, Models *ST100A* and *ST102AA* *without* packing gland option:

NEMA 4X, IP67; polyester powder coated aluminum; 2 conduit ports threaded as 1/2" NPT or M20x1.5; 3.75" x 4.00" x 3.24" [95 mm x 102 mm x 82 mm]

Models *ST100A* and *ST102AA* *with* packing gland option; *ST110A, ST112AA* and all *STP* Models:

NEMA 4X, IP67; polyester powder coated aluminum; 1 conduit port threaded as 1" NPT or M20x1.5; 5.40" x 4.82" [137,2 mm x 122 mm]

All models with stainless steel enclosure option:

NEMA 4X, IP67; stainless steel; 1 conduit port threaded as 1" NPT or M20x1.5; 5.40" x 4.82" [137,2 mm x 122 mm]

Data Logger

User programmable for readings per time increment to a maximum of 1 reading/second; removable, circuit board-mountable 8 GB micro-SD (secure digital) memory card supplied; stores approximately 80 M readings in ASCII comma-separated format

Readout/Display and Optical Touch Buttons *Optional*

- Large 2" x 2" [50 mm x 50 mm] LCD; digital plus bar graph and engineering units
- Digital displays of flow rate, total flow, temperature and pressure (with STP models); user selectable for engineering units
- Analog bar graph of flow rate
- Alarm status indication
- User programmable 17 alphanumeric character field associated with each calibration group
- Set-Up & Service mode displays text and service codes
- Backlighting
- Four (4) optical touch buttons for user programming of instrument set-up and service interrogation
- Optical touch button activation through front window – no need to open enclosure to access or activate
- Display is electronically rotatable in 90° increments to optimize viewing angle

Note: If readout/display not ordered, all user set-up and service interrogation must be done via computer link to bus comm and/or USB port.

Other Options

Vortab Flow Conditioners

Available for all line size applications; standard choice with Model *ST100AL* (in-line)

Sun Shield

Shades main transmitter, electronics and display from direct sunlight; 316L stainless steel

FCI PN 023241-01 *Integral transmitter*

FCI PN 023237-01 *Remote transmitter*

Ball Valves/Cable Glands

Element Coatings and Materials

For service in highly corrosive gases or with erosive particulates, FCI can provide special coatings and wetted materials to protect the element and provide longer service life; examples include Kynar, Tantalum, and chromium carbide

Certification and Testing Documentation

Specifications at reference operating conditions of 70 °F, 14.7 psia [21,1 °C, 1013 bar(a)] and straight pipe run 20 d upstream, 10 d downstream

FCI is a continuous improvement company; specifications subject to change without notice

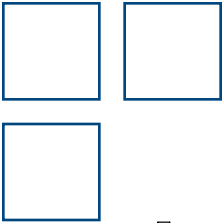

Model ST100AL In-Line Flow Meter

Integral Configuration

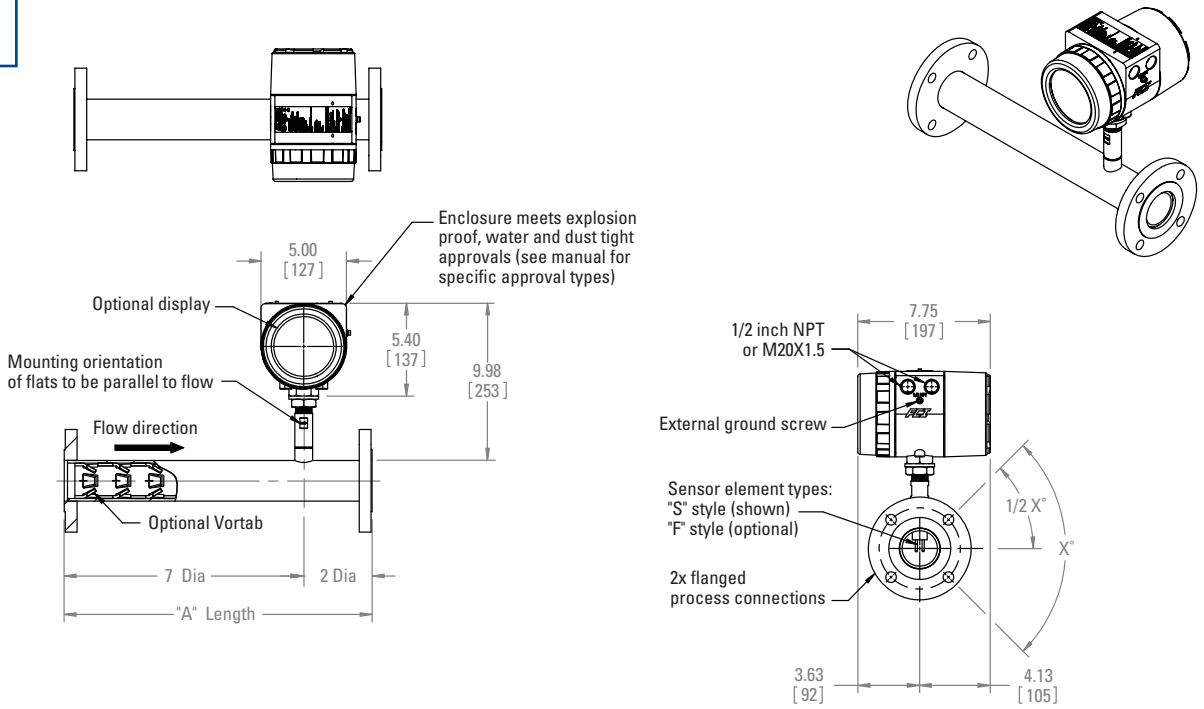

Remote Transmitter

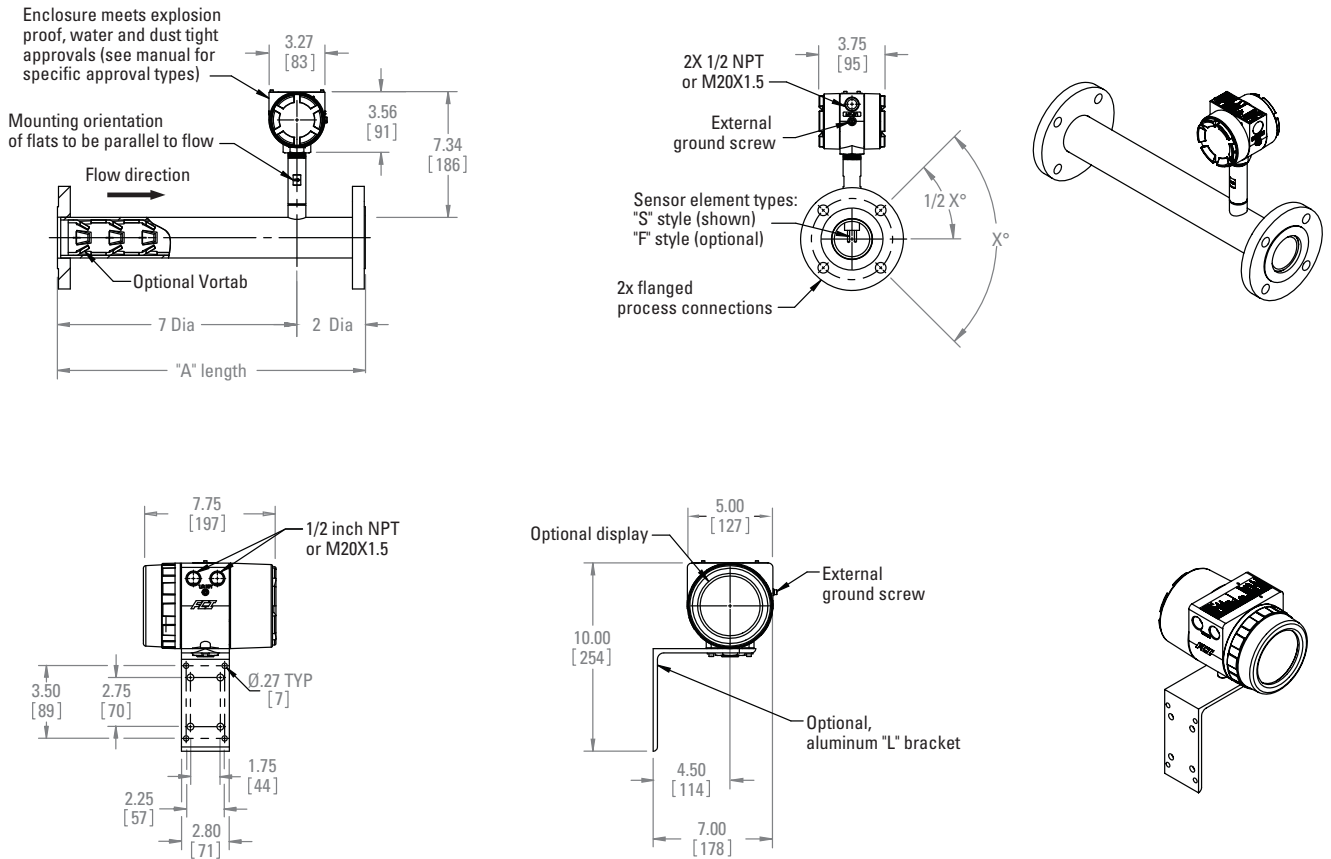

Model ST100A Single-Point, ST102AA Dual-Element Insertion Flow Meter

Integral Configuration

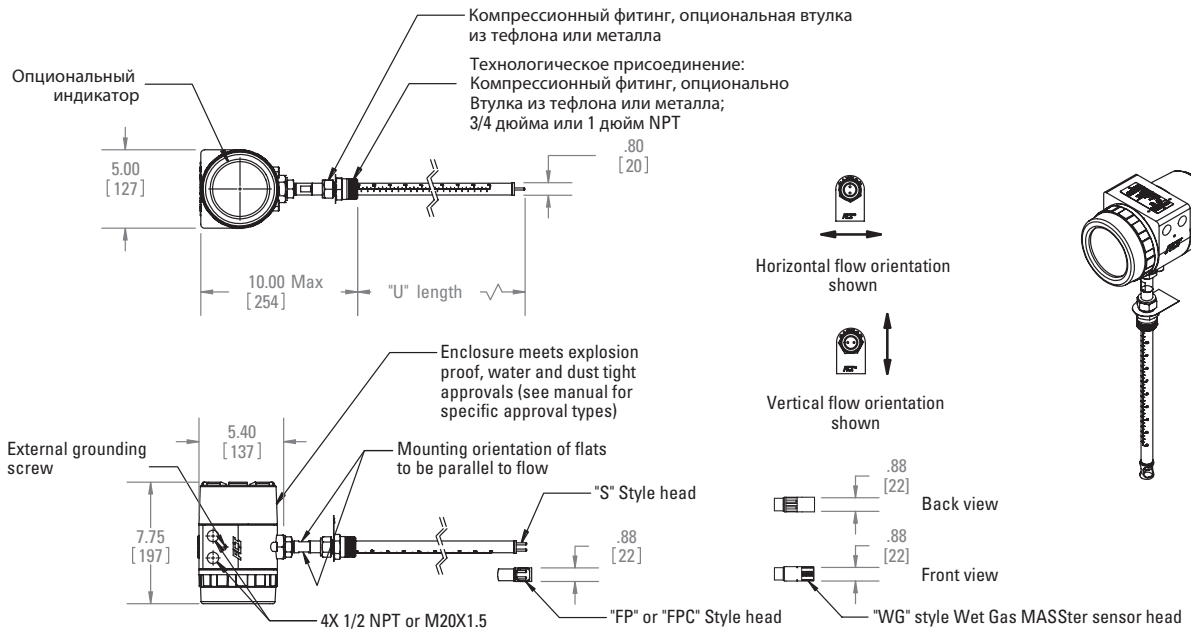
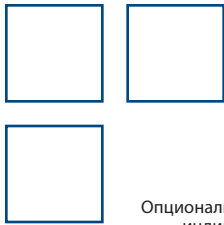

Remote Transmitter

With Ferrule Type Compression Fitting

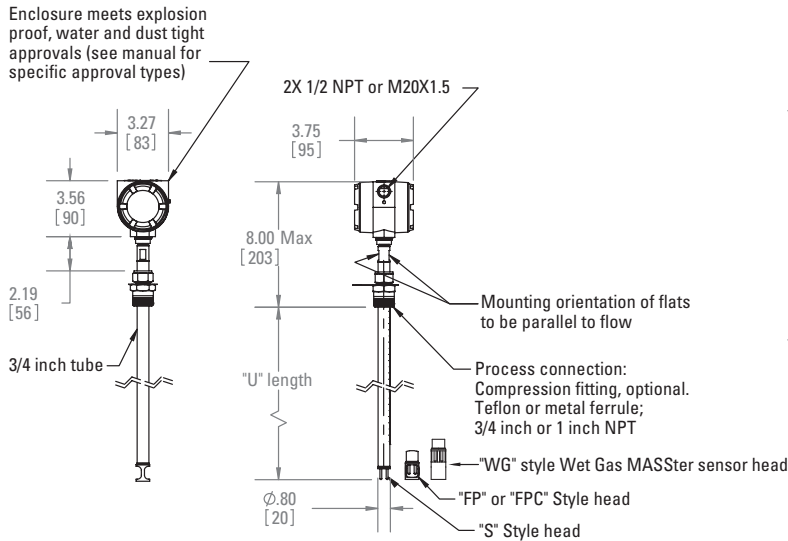

With Packing Gland

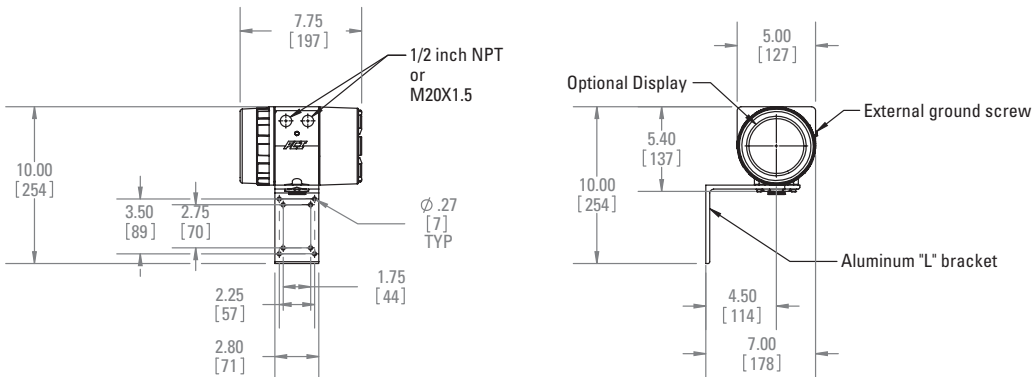
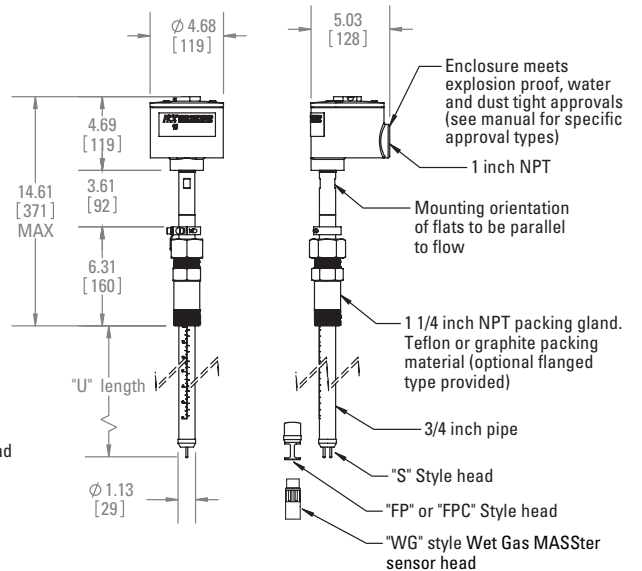

Model ST110A Single-Point, ST112AA Dual-Element Insertion Flow Meter

Integral Configuration

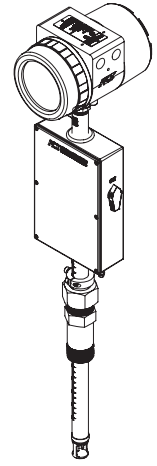
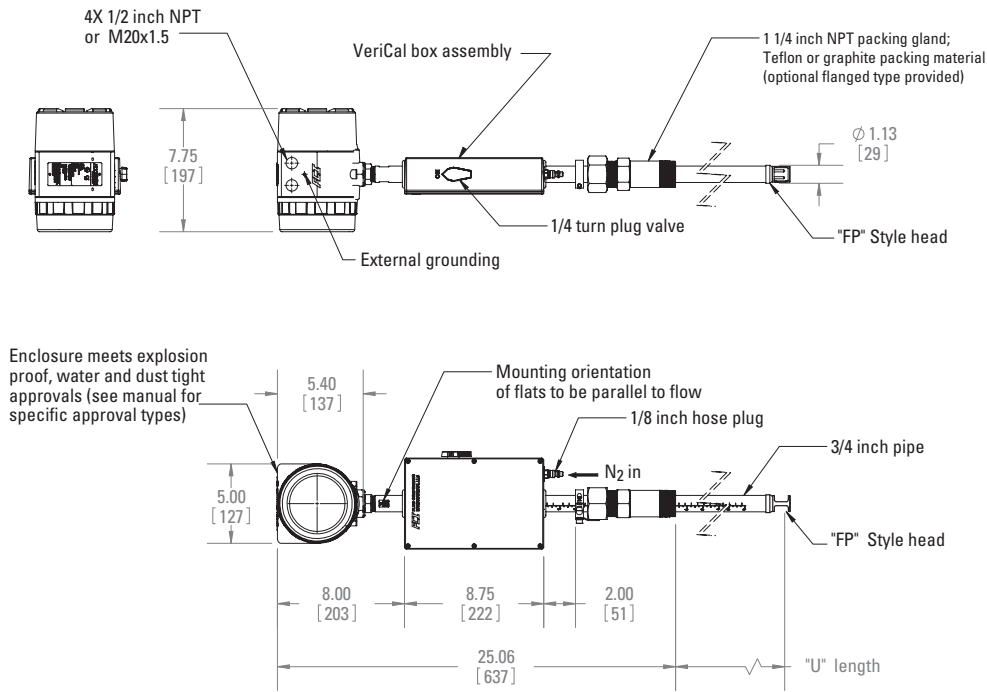

Remote Transmitter

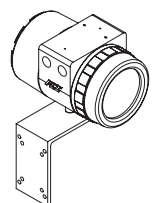
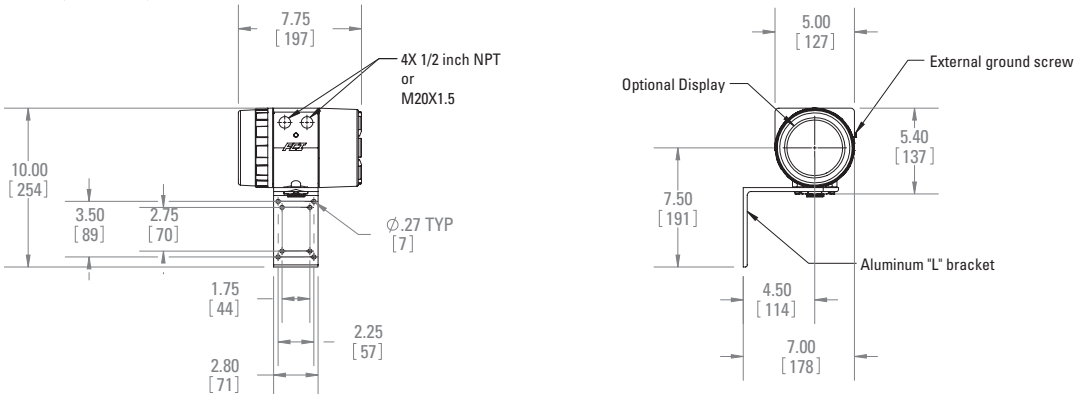
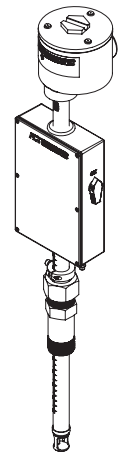
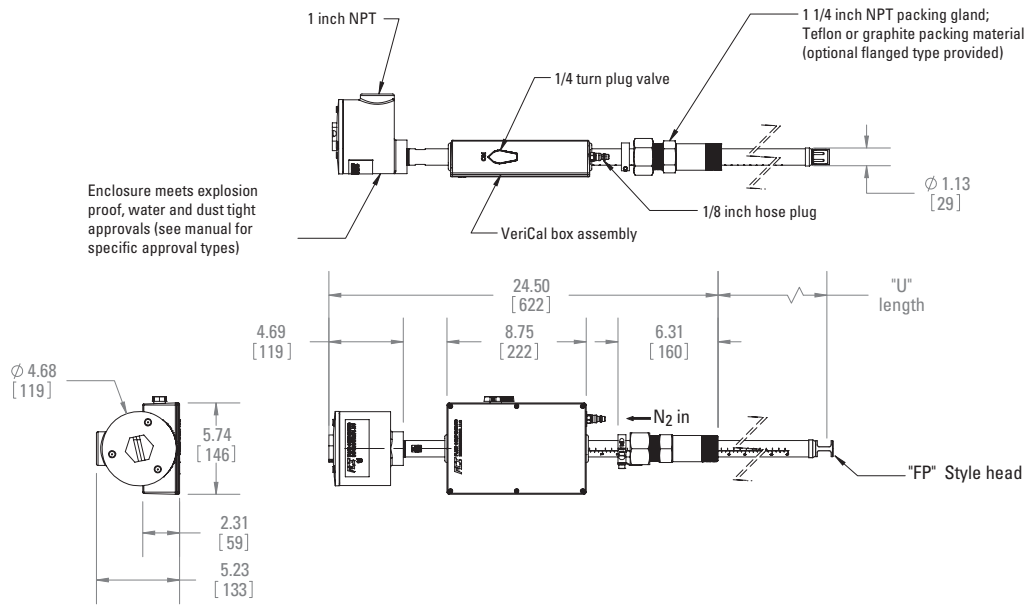

Model STP100A Single-Point Insertion Flow Meter

Integral Configuration

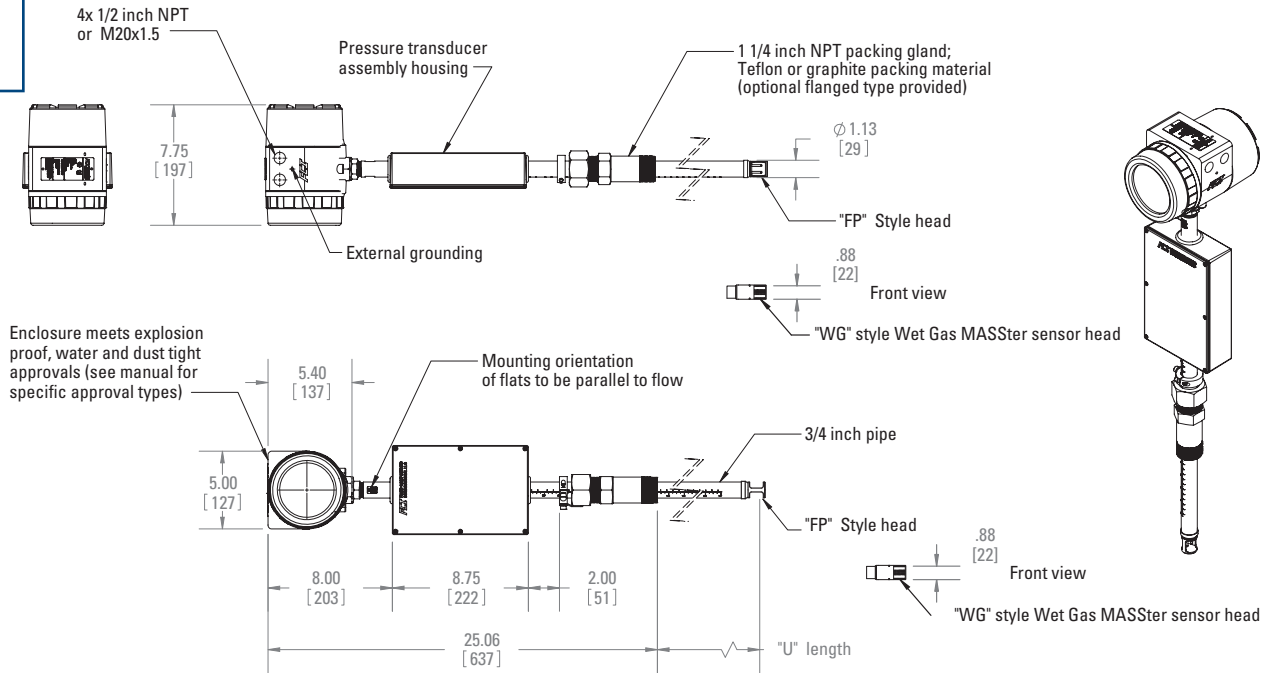
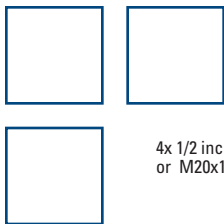

Remote Transmitter

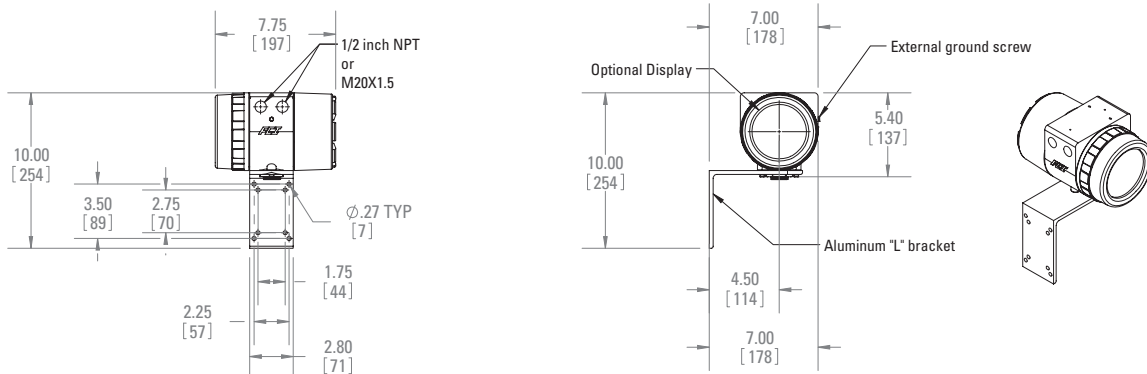
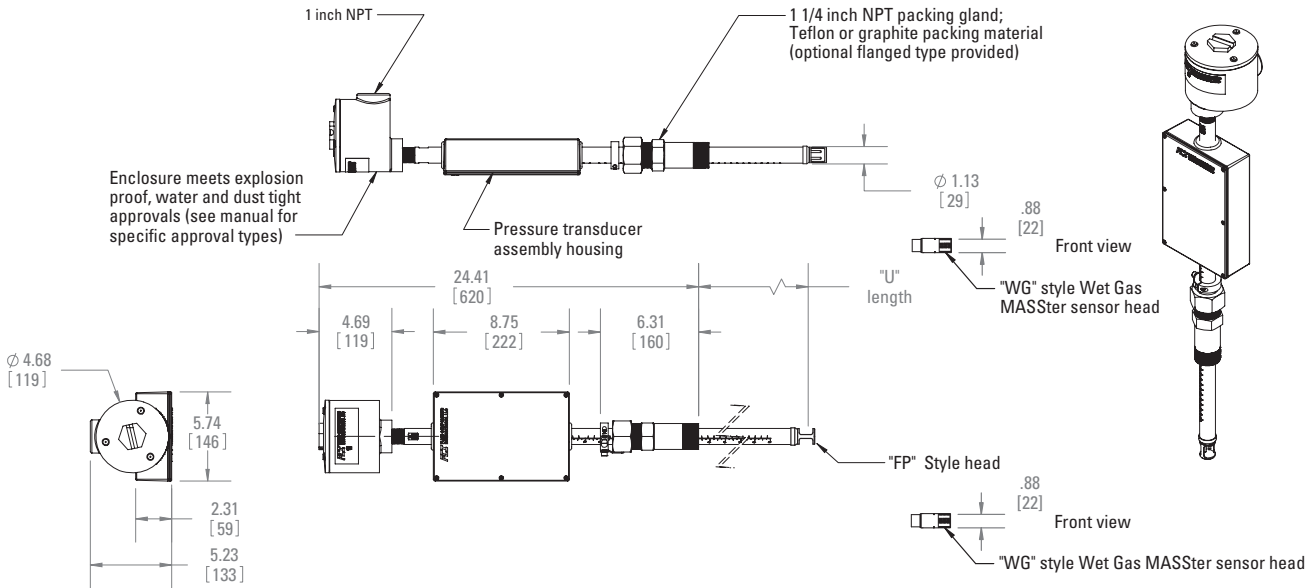

Model STP110A Single-Point Insertion Flow Meter

Integral Configuration

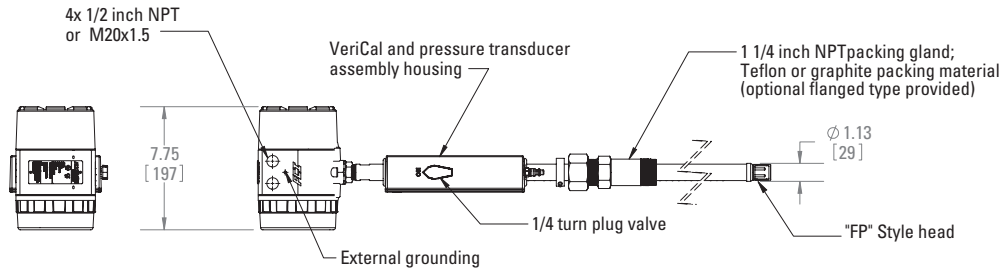

Enclosure meets explosion proof, water and dust tight approvals (see manual for specific approval types)

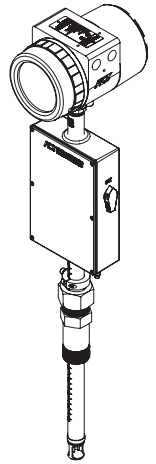
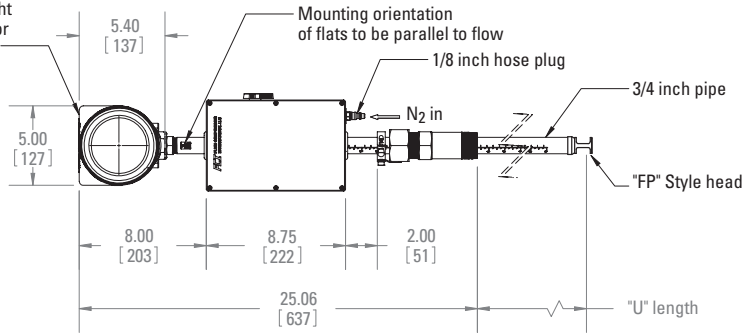

Remote Transmitter

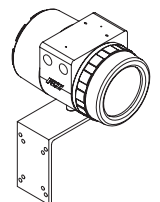
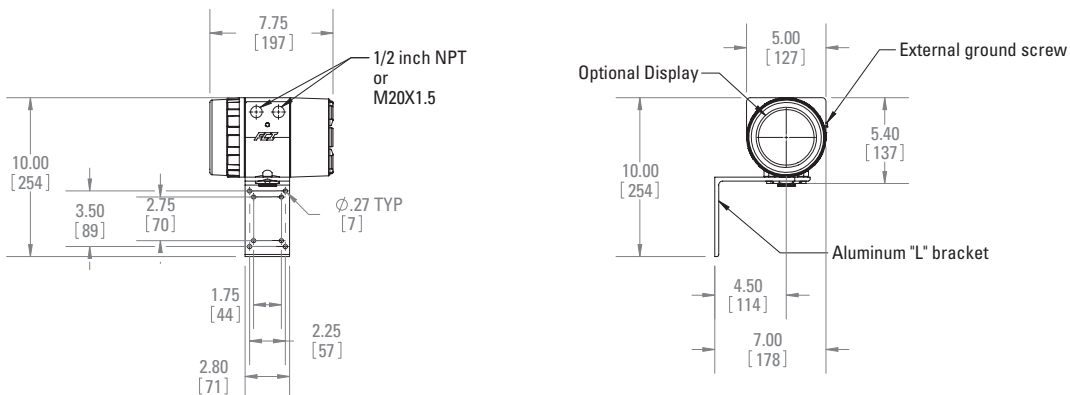
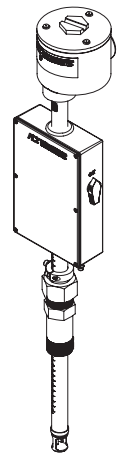
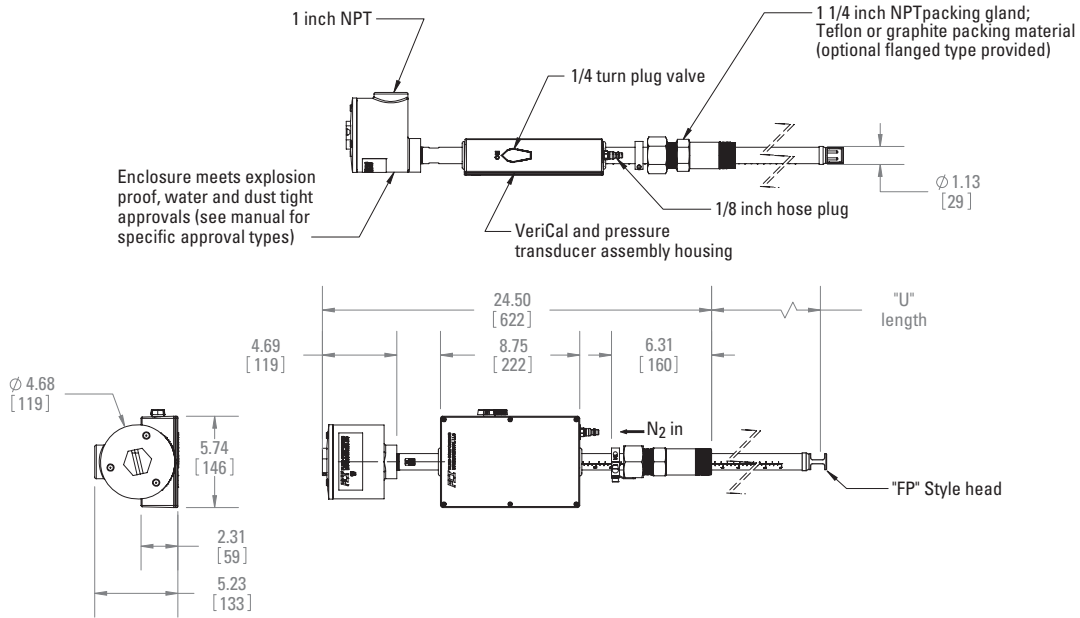

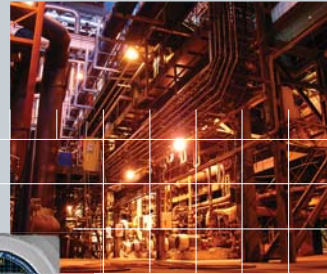
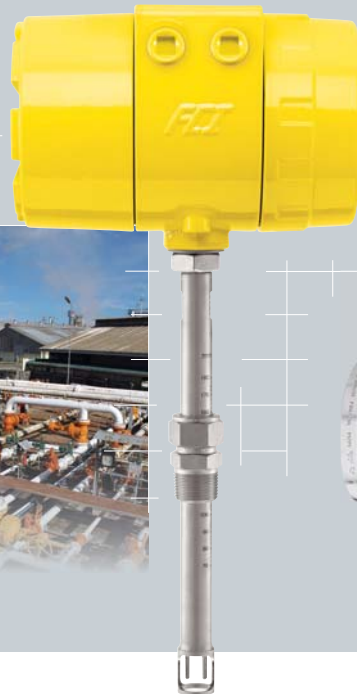
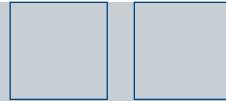
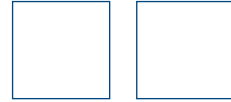
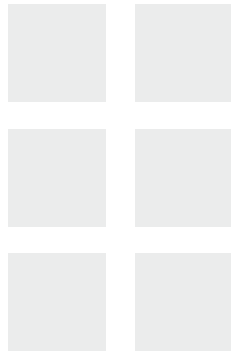

FCI FLUID COMPONENTS INTERNATIONAL LLC

A PST BRAND

Locally Represented By:

Visit FCI online at www.FluidComponents.com | FCI's Quality Management System is ISO 9001 and AS9100 Certified

FCI World Headquarters

1755 La Costa Meadows Drive | San Marcos, California 92078 USA
Phone: 760-744-6950 Toll Free (US): 800-854-1993

FCI Europe

Persephonestraat 3-01 | 5047 TT Tilburg, The Netherlands | Phone: 31-13-5159989

FCI Measurement and Control Technology (Beijing) Co., LTD

Room 107, Xianfeng Building II, No.7 Kaituo Road, Shangdi IT Industry Base, Haidian District | Beijing 100085, P. R. China
Phone: 86-10-82782381



1223

Copyright 2020-2024 by Fluid Components International LLC. All rights reserved. Manufactured in accordance with one or more of the following patents: US Patent Numbers 7,201,033; 8,806,955; 9,010,994 (CN, DE, GB, KR, NL); 9228881; 9528868; 9671265; 11,105,666 (CA, CN, DE, GB, KR); China Patent Number 2017800582146; and other US and foreign applications pending FCI and FCI design, FLT, Vortab, FCI Nuclear and FCI Nuclear design are registered trademarks of Fluid Components International LLC. Information subject to change without notice.

HART® is a registered trademark; Foundation™ Fieldbus is a trademark of FieldComm Group; PROFIBUS® is a registered trademark of PROFIBUS.

Doc. No. 02MK011555 C