

- For continuous level measurement of liquids (even if polluted), mash and paste materials in open or closed vessels, sumps, open channels, drains, etc.
- Quick view measured values on the display
- Easy adjustment without measured material
- Elimination of false echoes
- Zone temperature compensation
- Possibility of using in explosive areas (version Xi)
- Current output (4 ... 20 mA) with HART[®] protocol or output RS-485 Modbus
- Copying of level meter configuration using display module DM-70
- While used with horn adapter can be measured also some difficult media (foamy levels, bulk solids, etc.)



The **ULM[®] ultrasonic level meters** are compact measurement devices including an electroacoustics converter, central processor unit and display module. Using the electroacoustics converter, the level meters transmit the sequence of ultrasonic pulses that spread towards the surface level. The converter recuperates reflected acoustic waves that are subsequently processed in the electronic module. The intelligent evaluation block filters out interfering signals, compares the cleaned received signal with the false reflection map (e.g. from mixers, ladders, reinforcement etc.) and selects a suitable reflection (echo). Based on the period during which the individual pulses spread towards the surface level and back and based on the measured temperature in the tank, the instant distance to the surface level is calculated. According to the level height, the level meter output is set: current 4-20 mA with HART[®] protocol or output RS-485 Modbus and the measured value is displayed on the display.

The level meters are suited to level measurement of various liquid materials, sewerage waters, mash and paste materials, suspensions in closed or open vessels, sumps, reservoirs and open channels. In case the level of bulk solids is measured, the measurement range is reduced. We recommend to consult the use with the manufacturer.

VARIANTS OF SENSORS

- **ULM-70_-02** **Measuring range from 0,15m do 2m**, plastic PVDF transmitter and plastic body (PP+HDPE), process connection with thread G 1".
- **ULM-70_-06** **Measuring range from 0,25m do 6m**, plastic PVDF transmitter and plastic body (PP+HDPE), process connection with thread G 1 ½".
- **ULM-70_-10** **Measuring range from 0.4m to 10m**, plastic PVDF transmitter and plastic body (PP+HDPE), process connection with thread G 2 ¼".
- **ULM-70_-20** **Measuring range from 0.5m to 20m**, with plastic PVDF transmitter and plastic body (PP+HDPE), aluminium alloy flange.

DIMENSIONAL DRAWINGS

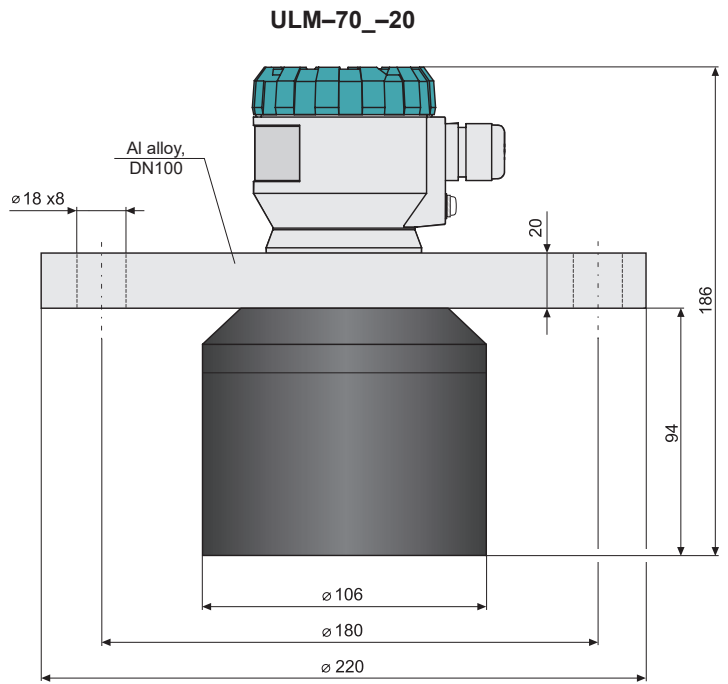
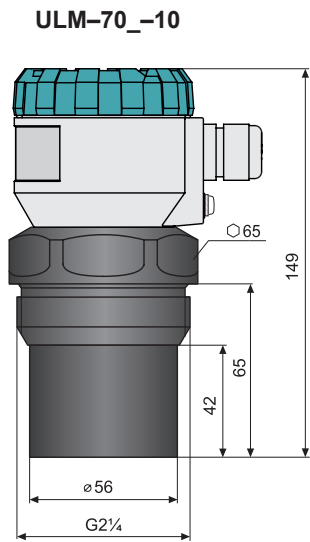
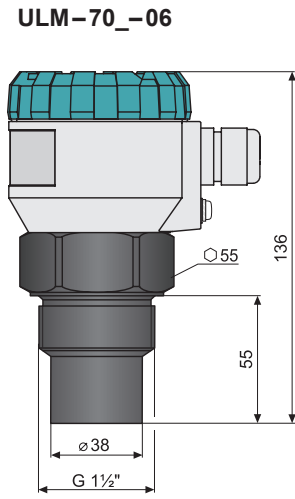
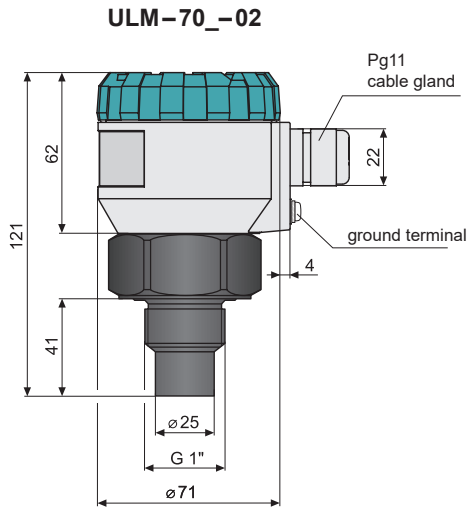

variant ULM-70 with protective conductor

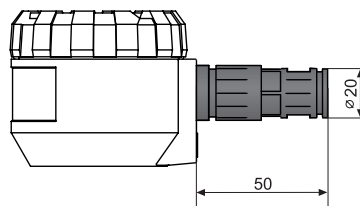

Flange (for type 20) according to standard: DIN 2527, PN10

| TECHNICAL SPECIFICATIONS – LEVEL METER | | |
|--|--|--|
| Measuring range ¹⁾ | ULM-70_-02 ULM-70_-06 ULM-70_-10 ULM-70_-20 | 0.15 ... 2 m 0.25 ... 6 m 0.4 ... 10 m 0.5 ... 20 m |
| Adjustable measuring range (SPAN) | | Min. 200 mm |
| Supply voltage | ULM-70_-__ ULM-70Xi-__ | 18 ... 36 V DC 18 ... 30 V DC |
| Output | ULM-70_-__-I ULM-70_-__-M | 4 ... 20 mA (Limit values 3.9 ... 20.5 mA), HART® RS-485 with protocol Modbus RTU |
| Current consumption | ULM-70_-__-I ULM-70_-__-M | 4 ... 20 mA / Max. 22 mA Max. 20 mA |
| Resolution | ULM-70_-02; 06 ULM-70_-10 ULM-70_-20 | < 1 mm < 2 mm < 2,5 mm |
| Accuracy (within the total range) | | 0,15 % |
| Temperature error | | Max. 0,04% / K |
| Operating frequency | ULM-70_-02 ULM-70_-06 ULM-70_-10 ULM-70_-20 | 120 kHz 75 kHz 50 kHz 30 kHz |
| Beamwidth (-3 dB) | ULM-70_-02; 10 ULM-70_-06 ULM-70_-20 | 10° 14° 12° |
| Ambient temperature range | ULM-70_-02; 06 ULM-70_-10; 20 | -30 ... +70°C -30 ... +60°C |
| Short-time temperature stress resistance | | +90°C / 1 hod. |
| Max. operation overpressure (on transmission surface) | | 0,1 MPa |
| Sensitivity | | 3 stupně (low – medium – high) |
| Damping | | 0 ... 99 s |
| Measuring period | | 1 ... 4 s |
| Rise time | | cca. 30 s |
| Additional technical data for Ex proof – Max. internal values | | U _i =30V DC; I _i =132mA; P _i =0,99W; C _i =370nF; L _i =0,9mH |
| Failure indication (echo loss, level in dead zone ³⁾ , internal failure) | | Adjustable in modes: 3.75 mA ; 22 mA ; Last measured value |
| Protection class | | IP67 |
| Mechanical connection | ULM-70_-02 ULM-70_-06 ULM-70_-10 ULM-70_-20 | Screwing with thread G 1" Screwing with thread G 1½" Screwing with thread G 2¼" Aluminium alloy flange |
| Recommended cable | ULM-70_-__-I ULM-70_-__-M | PVC 2 x 0,75 mm ² PVC 2 x 2 x 0,25 mm ² (twisted pair, shielded) |
| Maximal resistance of current output load | U = 24 V DC U = 22 V DC U = 20 V DC | R _{max} = 270 Ω ²⁾ R _{max} = 180 Ω R _{max} = 90 Ω |
| Weight | ULM-70_-02 ULM-70_-06 ULM-70_-10 ULM-70_-20 | 0.3 kg 0.4 kg 0.7 kg 3.1 kg |

¹⁾ In case the level of bulk-solid materials is measured, the measurement range is reduced.

²⁾ Including 250R resistor in case of HART connection.

| TECHNICAL SPECIFICATIONS – DISPLAY MODULE | |
|--|-----------------------|
| Display type | Matrix OLED |
| Resolution | 128 x 64 pixel |
| Character height / Number of digits measured value | 9 mm / 5 Digits |
| Display colour | Yellow |
| Buttons | Membrane switch panel |
| Ambient temperature range | -30 ... +70 °C |
| Weight | 46 g |

AREA CLASSIFICATION (according to EN 60079-10 and EN 60079-14)

| | |
|----------------------------|--|
| ULM-70N-__ | Performance for non-explosive areas |
| ULM-70Xi-02 ULM-70Xi-06 | Explosive proof – suitable for explosive areas (combustible gases or vapours) ⒺII 1/2G Ex ia IIB T5 Ga/Gb with Isolating repeater (IRU-420), the whole level meter – zone 1, front head part – zone 0 |
| ULM-70Xi-10 | Explosive proof – suitable for explosive areas (combustible gases or vapours) ⒺII 1/2G Ex ia IIA T5 Ga/Gb with Isolating repeater (IRU-420), the whole level meter – zone 1, front head part – zone 0 |
| ULM-70Xi-20 | Explosive proof – suitable for explosive areas (combustible gases or vapours) ⒺII 2G Ex ia IIA T5 Gb with Isolating repeater (IRU-420), the whole level meter – zone 1 |

INSTALLATION

Level meter is installed into the upper lid of the tank (vessel), using a fixing nut or a flange.

If installed in an open channel (sumps, reservoirs, etc.), install the level meter as close as you can to the maximum level expected.

The front of the level meter must be vertically to the measured level.

Foam on the level absorbs the acoustic wave reflection which might cause malfunction of the level meter. If possible select the location where the foaming is as low as possible.

Protect the level meter against direct sunlight.

In the case of uncertainty we recommend to consult the application with the producer.

MOUNTING RECOMMENDATION

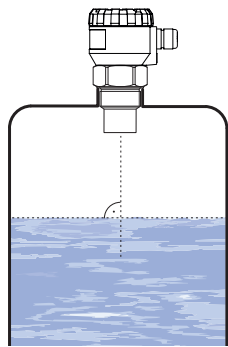

Recommended installation

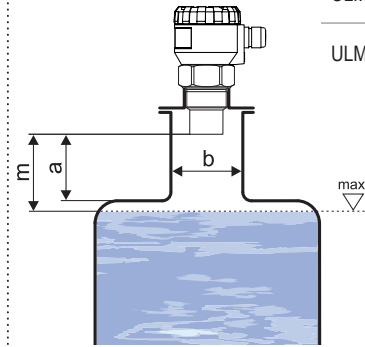

| | |
|----------------|------------------------------------|
| ULM-70_-02; 06 | $a < 3b$ $b > 100 \text{ mm}$ |
| ULM-70_-10 | $a < 1,5b$ $b > 100 \text{ mm}$ |
| ULM-70_-20 | $a < 1,5b$ $b > 150 \text{ mm}$ |

a - neck height
b - neck width
m - dead zone

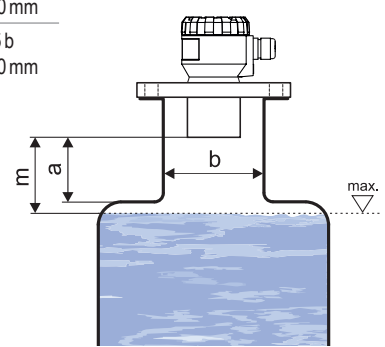

Possible installation through the neck

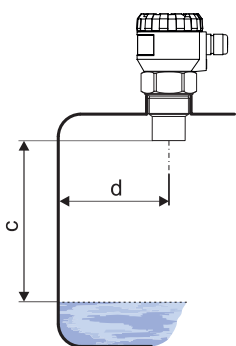

c - measuring range
d - min. distance from tank wall

| | |
|----------------|-------------------------------|
| ULM-70_-02; 10 | $d > 1/12 c$ (min. 200 mm) |
| ULM-70_-06 | $d > 1/8 c$ (min. 200 mm) |
| ULM-70_-20 | $d > 1/10 c$ (min. 200 mm) |

Installation distance from the tank wall

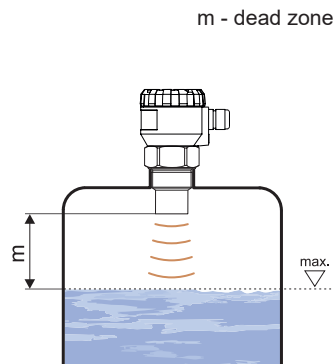

m - dead zone

Maximum level distance from ULM

ELECTRICAL CONNECTION

The level meter is connected to consequential (evaluating) device with a suitable cable with the outer diameter of 6 to 8 mm using screw terminals located under the display module. The recommended cross section of cores for the current version $2 \times 0,5 \div 0,75 \text{ mm}^2$ and for the version with Modbus communication $2 \times 2 \times 0,25 \text{ mm}^2$ (twisted pair, shielded). Plus pole (+U) is connected to the terminal (+), minus pole (0 V) to the terminal (-) and the shielding (only for shielded cables) to the terminal (\perp). Communication wires A and B of the line RS-485 (for version "M" - Modbus) are connected to the terminals A and B.

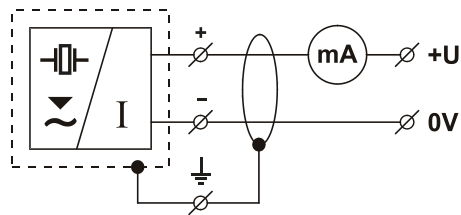

Wiring diagram of the level meter with current output ULM-70_---I

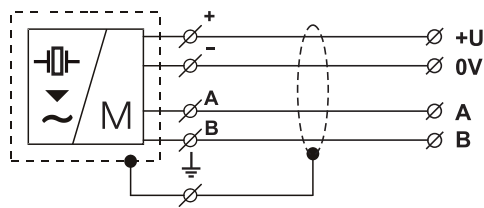

Wiring diagram of the level meter with Modbus ULM-70_---M

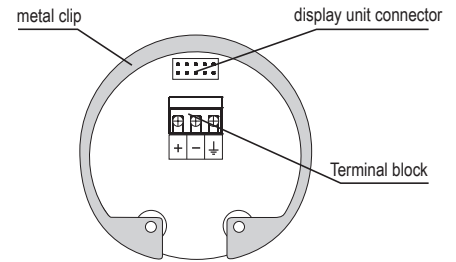

Inside view of screw terminals of the level meter with current output ULM-70_---I

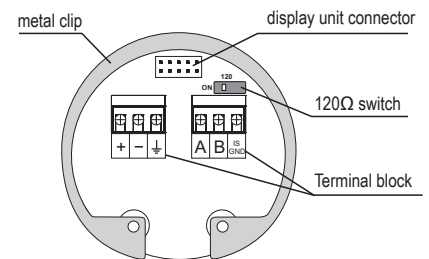

Inside view of screw terminals of the level meter with Modbus ULM-70_---M

Electrical connection must be done in de-energized state!

The supply voltage source should be preferably realized as a stabilized power supply unit with safe voltage from 18 to 36 V DC ($18 \div 30 \text{ VDC}$ for Xi version), which can be a part of the evaluation or display device.

With regard to possible occurrence of electrostatic charge on non-conductive parts of the level meter, all level meters for explosive spaces (ULM-70Xi type) must be grounded. It will be done using a screw placed on the head of the level meter under the cable outlet.

In case of strong electromagnetic interferences (EMI), parallel cable ducting with power lines, or when cable length exceeds 30 m we recommended to use shielded cable.

LEVEL METER SETTING

Set the level meter using 3 buttons placed on the display module. All settings are accessible in the ULM-70 set-up mode access. For detailed information please read at the instructions manual.

Button

- Set-up mode access
- Confirmation of selected item in the menu
- Move the cursor in the line
- Saving of set-up data

Button

- Move in the menu
- Change of values

Button

- Cancelling of carried out changes
- Shift one level up

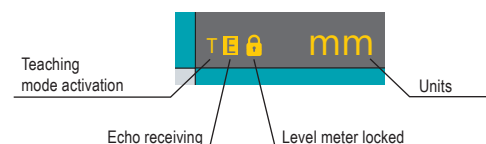
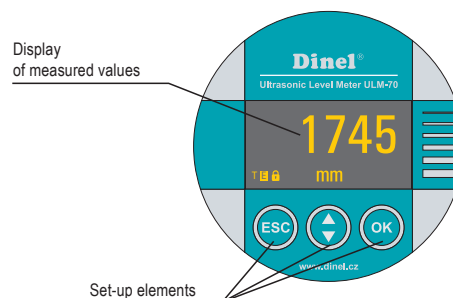

* Slow flashing while the reflected signal (echo) is received from the measured level.

RANGE OF APPLICATIONS

For continuous non-contact level measurement of liquids (water solutions, sewerage water, etc.), mash and paste materials (sediments, sticks, resins etc.) in closed or open vessels, sumps, reservoirs and open channels. In case the level of bulk-solid materials is measured, the measurement range is reduced. We recommend to consult the use with the manufacturer

ORDER CODE

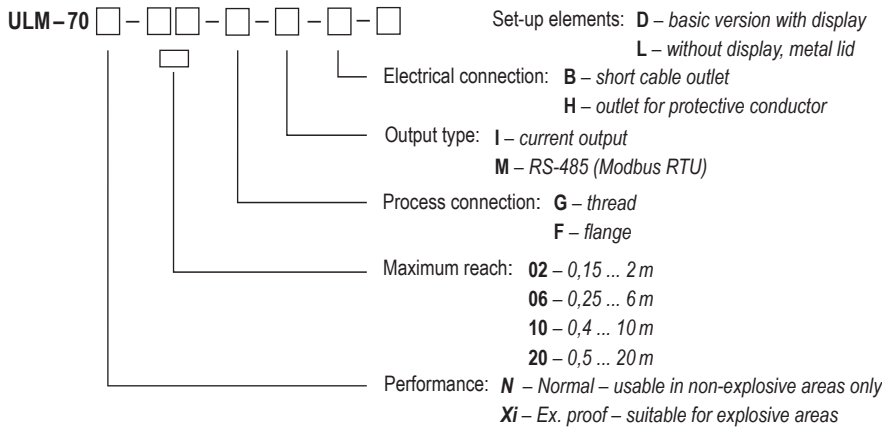

CORRECT SPECIFICATION EXAMPLES

ULM-70N-02-G-I-B-D
ULM-70Xi-06-G-I-H-L

ULM-70N-10-M-H-L
ULM-70Xi-20-F-I-B-D

ACCESSORIES

Standard – incl. in the price of the level sensor

- 1 pc of Seal (for ULM-70_02-I, 06-I)
- for version with Modbus software
Basic Scada Level is possible to download

Optional – for extra charge

- Fixing nuts G1" and G1 ½"
- Horn adapter ST-G1 and ST-G1,5
- for version with Modbus convertor URC-485

SAFETY, PROTECTION, COMPATIBILITY AND EXPLOSION PROOF

The level meter ULM-70 is equipped with protection against reverse polarity and output current overload.

Protection against dangerous contact is secured by low safety voltage that complies with EN 33 2000-4-41.

Electromagnetic compatibility according to EN 55022/B, EN 61326/Z1 and EN 61000-4-2 to 6.

Explosion proof of ULM-70Xi type complies with the following standards: EN 60079-0 : 2007;

EN 60079-11 : 2007 ; EN 60079-26 : 2007 and examined by FTZÚ-AO 210 Ostrava - Radvanice certificate No.: FTZÚ 09 ATEX 0277X.

Special conditions for safe use ULM-70Xi:

The device is designed for connection to the isolating repeater IRU-420. When the other approved supply unit is used, whose output parameters satisfy above mentioned output parameters, it is necessary to have a galvanic separation or, if supply unit without galvanic separation is used (Zener barriers), it is necessary provide potential equalization between sensor and point of barrier earthing.

For application in zone 0 the present explosive atmospheres - mixture of air with flammable gases, vapour or mists must comply: $0,8 \text{ bar} < p < 1,1 \text{ bar}$. The device must be installed in such a way, to prevent mechanical damage of sensor face. It is necessary carried out earthing by screw which is placed on head of level meter.

ULM a Dinel are registered trademark of company Dinel s.r.o.

ULM-70-dat-6.6



QMS
ISO 9001

Dinel, s.r.o.
U Tescomy 249
760 01 Zlín, Czech Republic

Phone: +420 577 002 003
Fax: +420 577 002 007

sale@dinel.cz
www.dinel.cz