

# bar-stock thermowells, weld-in connection, NP 100...250

# W70 serie



Thermowells are used to protect the measuring instrument from corrosion, high pressure or high fluid velocity and to allow the measuring instrument removal for recalibration or replacement without affecting the process system. The W72-W73 serie includes bar stock thermowells with weld-in socket process connection and they are suitable for heavy work conditions. These thermowells are suitable for low / medium work intensity. These thermowells have a stepped-shank immersion length for a better process temperature measuring sensibility. The W75-W75 serie includes bar stock thermowells with weld-in socket process connection and they are suitable for heavy work conditions. These thermowells have a conic immersion length.

## 9 - Thermowells

### Nominal pressure:

stepped shank : 11450 psi @ 752°F (100 bar @ 400°C);

tapered shank : 3600 psi @ 752°F (250 bar @ 400°C).

**Process fluid temperature:** -328...+1112°F (-200...+600°C), for std materials.

**Total length:** max 40" (1000 mm).

**Materials :** AISI 316 (Cod. 4), AISI 316L (Cod. 5) st.st. bar-stock.

**Special materials :** Monel 400, Hastelloy C276, Alloy 825, Alloy 625, Duplex SAF 2205, Duplex SAF 2507 bar-stock.

## OPTIONS

<b>P02</b> - Oxygen service
<b>E30</b> - NACE MR0103 - MR0175 (ISO15156) certificate
<b>TC1</b> - Plug and chain (1)
<b>NIP</b> - Nipple with coupling (1)
<b>CVK</b> - Von Karman Trail calculation (1) (2)

(1) Drawings and details in the "Thermowells information" sheet.

(2) Available for tapered shank only.

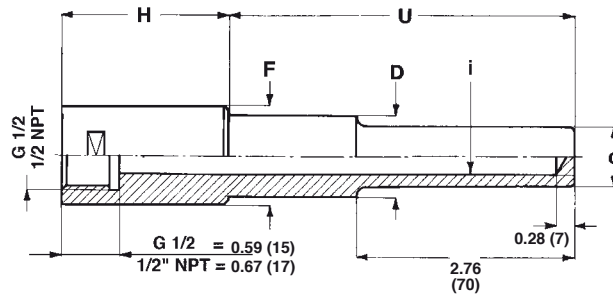

Mod.	DN	F	i	D	d	H
W72	3/4"	1.06 (26,9)	0.28-0.31-0.35 (7 - 8 -9)	0.75 (19)	0.59 (15)	1.81 (46)
			0.39-0.47 (10 - 12)	0.75 (19)	0.71 (18)	
W73	1"	1.31 (33,4)	0.28-0.31-0.35 (7 - 8 -9)	0.87 (22)	0.59 (15)	2.01 (51)
			0.39-0.47 (10 - 12)	0.87 (22)	0.71 (18)	

dimensions : inches (mm)

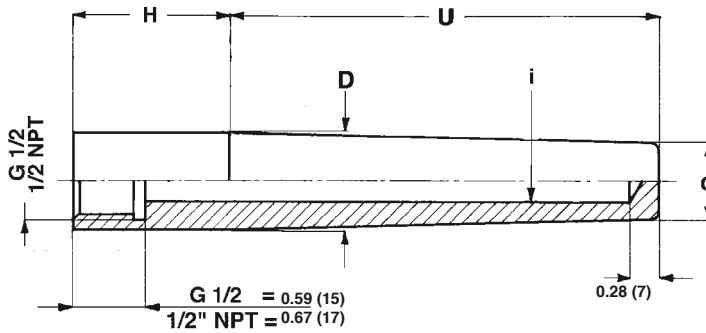

Mod.	DN	i	D	d	H
W74	1"	0.28-0.31-0.35 (7 - 8 -9)	1.31 (33,4)	0.71 (18)	2.01 (51)
		0.39-0.47 (10 - 12)		0.83 (21)	
W75	1"1/4	0.28-0.31-0.35 (7 - 8 -9)	1.66 (42,16)	0.71 (18)	2.01 (51)
		0.39-0.47 (10 - 12)		0.83 (21)	

dimensions : inches (mm)

i
070 - ø 0.28 (7)
080 - ø 0.31 (8)
090 - ø 0.35 (9)
100 - ø 0.39 (10)
120 - ø 0.47 (12)

**"HOW TO ORDER" SEQUENCE**

Section / Model / Material / Instrument connection / Process connection / Insertion hole / Insertion length / Extension length / Options

9	W72	4	41F - G 1/2	700	070	P02...CVK
	W73	5	43M - 1/2 NPT		080	
	W74				090	
	W75				100	
					120	