

Product Information

UR3K-010..050G / A M / K

Flow Switch
UR3K-...G / A

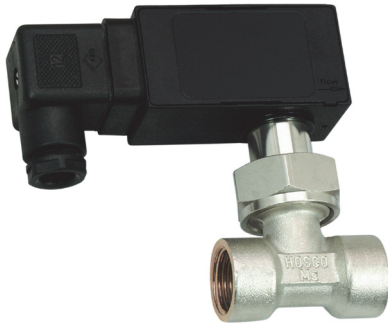

- Threaded connection
- Reed switch
- Low pressure loss
- Compact design
- Threaded connection
- Plug DIN 43650-A / ISO 4400

Characteristics

The devices function via the principle of a spring-supported paddle, and the magnetic triggering of a reed switch.

Technical data

Switch	reed switch	
Nominal width	DN 10..50	
Process connection	female thread G 3/8..G 1 (further process connections available on request)	
Switching range	3.5..69 l/min	for details see table "Ranges"
Q_{max.}	to 150 l/min	
Tolerance	±15 % of full scale value	
Pressure resistance	PN 25 bar	
Medium temperature	-20..+110 °C	
Ambient temperature	-20..+70 °C	
Media	water (oils, gases and aggressive media available on request)	
Wiring	normally open (n.o.) No. 0.372	
Switching voltage	max. 230 V AC	
Switching current	max. 1 A	
Switching capacity	max. 50 VA	
Protection class	2 - safety insulation	
Ingress protection	IP 65	
Electrical connection	plug DIN 43650-A / ISO 4400, optionally for round plug connector M12x1, 4-pole	
Materials medium-contact	<i>Brass construction:</i> CW617N nickelled, CW614N nickelled, 1.4310, 1.4301, hard ferrite, NBR	<i>Stainless steel construction:</i> 1.4305, 1.4571, 1.4310, 1.4310, Hard ferrite PTFE coated, FKM

Non-medium contact materials	ABS, PA, NBR
Weight	see table "Dimensions and weights"
Installation location	Standard: horizontal inwards flow; switching head not recommended underneath; other installation positions are possible; the installation position affects the switching point and range.

Ranges

Details in the table correspond to horizontal inwards flow with decreasing flow rate.

G	DN	Switching range l/min H ₂ O	Types	Q _{max.} recommended
G 3/8	DN 10	3.5 - 5.0	UR3K-010G.050	10
G 1/2	DN 15	5.0 - 6.5	UR3K-015G.065	20
G 3/4	DN 20	6.0 - 8.5	UR3K-020G.085	40
G 1	DN 25	12.0 - 15.0	UR3K-025G.150	60
G 1 1/4	DN 32	20.0 - 27.0	UR3K-032G.270	80
G 1 1/2	DN 40	34.0 - 44.0	UR3K-040G.440	100
G 2	DN 50	54.0 - 69.0	UR3K-050G.690	150

Special ranges are available.

Dimensions and weights

G	Types	H	L	X	Weight kg
G 3/8	UR3K-010GM	87	50	10	0.45
	UR3K-010GK				0.50
G 1/2	UR3K-015GM	92	50	10	0.40
	UR3K-015GK				0.45
G 3/4	UR3K-020GM	98	50	12	0.50
	UR3K-020GK				
G 1	UR3K-025GM	104	50	12	0.75
	UR3K-025GK				
G 1 1/4	UR3K-032GM	110	50	12	0.85
	UR3K-032GK				
G 1 1/2	UR3K-040GM	116	50	12	1.05
	UR3K-040GK				
G 2	UR3K-050GM	122	50	12	1.25
	UR3K-050GK				

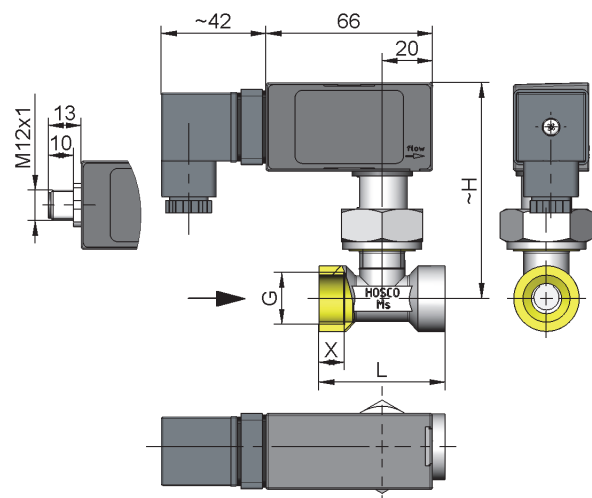

Product Information

UR3K-010..050G / A M / K

Handling and operation

Note

- Include straight calming section of 5 x DN in inlet and outlet
- When tightening the union nut, the connection piece must be countered using an open-ended spanner (SW 19).
- If the media are dirty, install a filter (use magnetic filter for ferritic components).
- It must be ensured that the values given for voltage, current, and power are not exceeded.
- When switched on, a load must be connected in series.
- The electrical details apply to ohmic loads. Capacitive, inductive and lamp loads must be operated using a protective circuit.

Adjustment

To adjust, open the slider. Adjustment is made using the adjustment screw with a lengthways slot; this is located under the valve.

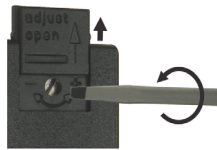

Turn clockwise for a lower switching point; turn anticlockwise for a higher switching point.

After adjustment, close the slider again.

Example: The adjustment range 20 to 27 l/min corresponds to 7 l/min Adjustment option in 7 revolutions. Adjustment is therefore 1 l/min for each revolution.

Ordering code

UR3K - 1. 2. 3. 4.
UR3K - **G**

1. Nominal width	
010	DN 10 - G 3/8
015	DN 15 - G 1/2
020	DN 20 - G 3/4
025	DN 25 - G 1
032	DN 32 - G 1 1/4
040	DN 40 - G 1 1/2
050	DN 50 - G 2
2. Process connection	
G	female thread
3. Connection material	
M	brass
K	stainless steel
4. Switching range H ₂ O for horizontal inwards flow	
050	3.5 - 5.0 l/min
065	5.0 - 6.5 l/min
085	6.0 - 8.5 l/min
150	12.0 - 15.0 l/min
270	20.0 - 27.0 l/min
440	34.0 - 44.0 l/min
690	54.0 - 69.0 l/min

Options

- Connection for round plug-in connector
- Signal lamp red or red/green in the plug DIN 43650-A
- Protective bellows
- Switching ranges for oil or gas
- Special values
- Soldered copper fitting
- Adhesive PVC fitting
- Male thread G 1/2 A - brass

Ordering information

- Specify direction of flow, medium, and switching range.
- For oils, state viscosity, temperature and designation (e.g. ISO VG 68) (enquire about range).
- For gases, state pressure (relative or absolute), temperature and medium (e.g. air) (enquire about range).