



MS1

bourdon tube pressure gauges standard execution DS 1.5", 2" (40-50mm)



PED 2014/68/EU

They can be used with gaseous or liquid media which do not corrode copper alloy and which do not have high viscosity or do not cristalize.

1.01.1 - Standard Model, DS 1.5" (40mm)

Design: EN 837-1.

Ranges: from 0...30 to 0...600 *psi* (from 0...2,5 to 0...40 bar or equivalent units)

Accuracy class: 1,6 as per EN 837-1.

Ambient temperature: -13...+122°F (-25°C...+50°C).

Process fluid temperature : +149°F (+ 65 °C max).

Thermal drift: max ±0,4 %/10 K of range (starting from 68°F - 20°C).

Working pressure:

75% of FSV for static pressure;

66% of FSV for pulsating pressure.

Overpressure (max 15 min):

25% of FSV for ranges ≤ 1500 *psi* (100 bar);

15% of FSV for ranges over 1500 *psi* (100 bar).

Protection degree: IP 40 as per IEC 529.

Socket material: copper alloy.

Bourdon tube: copper alloy.

Welding: copper alloy.

Case: stainless steel

Window: plastic.

Movement: copper alloy.

Dial: aluminium, white with black markings

Pointer: non adjustable, aluminium, black.

1.01.1 - Standard Model, DS 2" (50mm)

Ranges: from 0...30 to 0...6000 *psi* ; (from 0...2,5 to 0...400 bar or other equivalent units).

Ambient temperature: -13...+149°F (-25°C...+65°C).

Other features: as Standard Model, DS 1.5" (40mm).



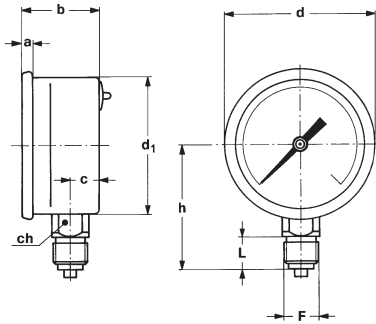

A - LOWER CONNECTION

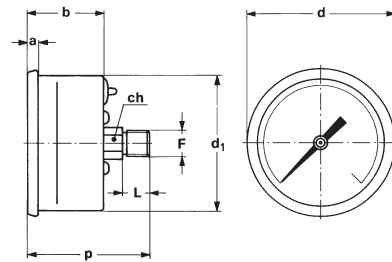

D - BACK CONNECTION

Mounting	DS	F	a	b	c	d	d ₁	h	p	L	ch	Weight
Back	A 1.5" (40)	11M - G 1/8 A		1.04"	0.43"	1.61"			1.77"	0.39"	0.47"	0.15 lbs
		13M - 1/8-27 NPT		(26,5)	(11)	(41)			(45)	(10)	(12)	(0,07 kg)
Lower	B 2" (50)	21M - G 1/4 A	0.15"	1.14"	0.43"	2.20"	2.00"			0.51"	0.55"	0.22 lbs
			(4)	(29)	(11)	(56)	(51)			(13)	(14)	(0,1 kg)
Lower	B 2" (50)	23M - 1/4-18 NPT	0.15"	1.14"		2.20"	2.00"	1.88"		0.59"	0.55"	0.22 lbs
			(4)	(29)		(56)	(51)	(47,9)		(15)	(14)	(0,1 kg)
Back	B 2" (50)	11M - G 1/8 A	0.15"	1.14"		2.20"	2.00"	1.88"	1.81"	0.39"	0.47"	0.18 lbs
		13M - 1/8-27 NPT	(4)	(29)		(56)	(51)	(47,9)	(46)	(10)	(12)	(0,085 kg)

dimensions : inches (mm)

"HOW TO ORDER" SEQUENCE

Section / Model / Case / Mounting / Diameter / Range / Process connection / Options

1 01 1 A A 11M
D B 13M
21M
23M

