

Product Information

NW1-020HM / K

Level Switch NW1

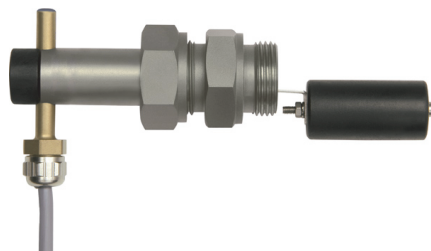

- Highly reproducible
- Normally open or normally closed contact

Characteristics

Mechanical level monitor for fluid media, with contact-free triggering of a reed contact.

Technical data

Switch	reed switch	
Process connection	male thread G 3/4 A	
Density of medium	Spansil float	³ 0.7 g/cm ³
	Stainless steel float	³ 0.9 g/cm ³
Pressure resistance	Spansil float	PN 25 bar
	Stainless steel float	PN 10 bar
	PVDF float	PN 25 bar
Medium temperature	-20..+110 °C (optional 150 °C)	
Ambient temperature	-20..+70 °C	
Media	water, oils	
Wiring	'normally open' or 'normally closed' No. 0.225	
Switching voltage	max. 230 V AC	
Switching current	max. 1 A	
Switching capacity	max. 50 VA	
Protection class	1 - PE connection	
Ingress protection	IP 65	
Electrical connection	cable 1.5 m	
Materials medium-contact	<i>Brass construction:</i>	<i>Stainless steel construction:</i>
	CW614N nickelled, 1.4301, 1.4571, Spansil (NBR), Hard ferrite, NBR	1.4305, 1.4571, Hard ferrite, FKM

Non-medium-contact materials	CW614N, nickelled, CW614N, NBR, PVC, POM
Weight	0.35 kg
Installation location	horizontal installation

Dimensions

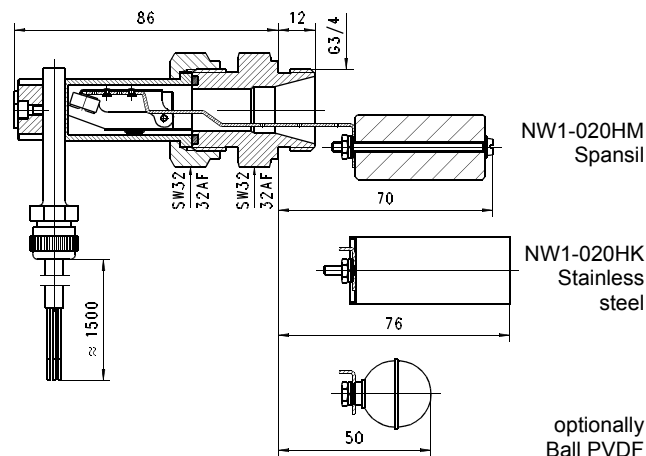

Handling and operation

- It must be ensured that the values given for voltage, current, and power are not exceeded.
- When switched on, a load must be connected in series.
- The electrical details apply to ohmic loads. Capacitive, inductive and lamp loads must be operated using a protective circuit.
- Not suitable for use in media with ferritic particles.

Ordering code

NW1 - 1. 2. 3. 4.
 020 H

○=Option

1. Connection size	020 threaded connection G 3/4 A
2. Process connection	H screw-in thread
3. Connection material	M brass K stainless steel
4. Switching unit option	○ for switching unit ATEX A-U1-2 A The switching unit must be ordered in addition.

Options

- Float ball PVDF
- Float cylinder stainless steel