

# bar-stock thermowells, tapered shank with flanged connection, NP 6...250

# W93



Thermowells are used to protect the measuring instrument from corrosion, high pressure or high fluid velocity and to allow the measuring instrument removal for recalibration or replacement without affecting the process system. The W93 serie includes bar-stock thermowells with flanged process connection and they are suitable for heavy work conditions. These thermowells have a conic immersion length.

## 9.W93 - Standard Model

**Nominal pressure:** as flange rating, 2900 psi @ 752°F max (250 bar @ 400°C).

**Process fluid temperature:** -328...+1112°F (-200...+600°C), for std materials.

**Total length:** max 40" (1000 mm).

**Process connection:** plain flanges as per DIN-UNI or ASME B16.5; dimensions and finishing as defined in "Thermowell information" sheet.

### Materials:

AISI 316 (Cod. 4) or AISI 316L (Cod. 5) st.st. bar-stock;  
ASTM A 105 (Cod. 3), AISI 316 (Cod. 4) st.st. flange.

**Special materials :** Monel 400, Hastelloy C276, Alloy 825, Alloy 625, Duplex SAF 2205, Duplex SAF 2507 flange and bar-stock (the flange is also available made by stainless steel, with wetted parts made by special material)

## OPTIONS

<b>P02</b> - Oxygen service
<b>E30</b> - NACE MR0103/MR0175 - ISO 15156-3 certificate
<b>TC1</b> - Plug and chain (1)
<b>NIP</b> - Nipple with coupling (1)
Double welding (1)
<b>FUL</b> - "full penetration" welding (1)
<b>P04</b> - Dye penetrant test (1)
<b>CVK</b> - ASME PTC 19.3 TW calculation (1)

(1) Drawings and details in the "Thermowells information" sheet.

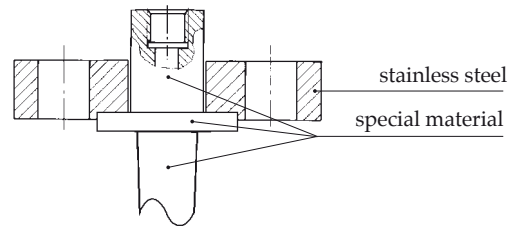
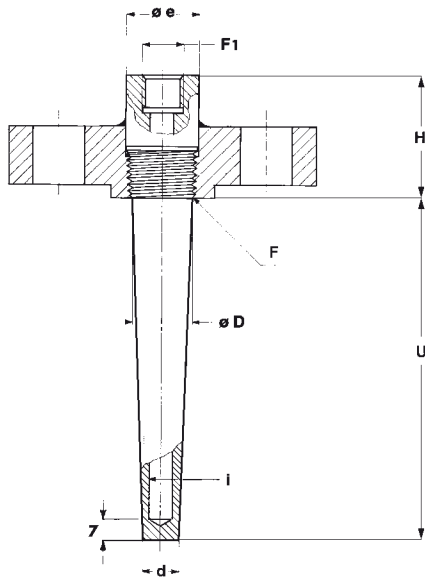

Version with stainless steel flange,  
but wetted parts made by special  
material

F1
41F - G 1/2
43F - 1/2-14 NPT
53F - 3/4-14 NPT

i
070 - $\varnothing$ 0.28 (7)
080 - $\varnothing$ 0.31 (8)
090 - $\varnothing$ 0.35 (9)
100 - $\varnothing$ 0.39 (10)
120 - $\varnothing$ 0.47 (12)

dimensions : inches (mm)

Standard (1)	DN		F	e	H	i	D	d
ASME B16.5	1"	Class 150...1500	3/4" NPT	1.18 (30)	2.36 (60)	0.28-0.31-0.35 (7 - 8 - 9)	0.91 (23)	0.71 (18)
						0.39-0.47 (10 - 12)	0.91 (23)	0.83 (21)
	1" 1/2 2"		1" NPT	1.38 (35)	2.36 (60)	0.28-0.31-0.35 (7 - 8 - 9)	1.14 (29)	0.71 (18)
						0.39-0.47 (10 - 12)	1.14 (29)	0.83 (21)
DIN-UNI	25	NP 6...100	3/4" NPT	1.18 (30)	2.36 (60)	0.28-0.31-0.35 (7 - 8 - 9)	0.91 (23)	0.71 (18)
						0.39-0.47 (10 - 12)	0.91 (23)	0.83 (21)
	32, 40, 50		1" NPT	1.38 (35)	2.36 (60)	0.28-0.31-0.35 (7 - 8 - 9)	1.14 (29)	0.71 (18)
						0.39-0.47 (10 - 12)	1.14 (29)	0.83 (21)

(1) flange dimensions are shown on introductory data-sheet "Introduction to thermowells"

"HOW TO ORDER" SEQUENCE

Section	Model	Material	Flange / material	Instrument / connection	Process / connection	Insertion hole / length	Insertion / length	Extension / length	Options
9	W93	4	3	41F	6AA	070			P02...CVK
		5	4	43F		080			
				53F		090			
						100			
						120			