

# HD403TS...; HD4V3TS...



## HD403TS... AND HD4V3TS... ACTIVE HOTWIRE AIR SPEED TRANSMITTERS

The **HD403TS...** series of hotwire air speed transmitters are used for measuring and controlling air speed in ventilation ducts, clean rooms, extractor fans, as well as monitoring air quality (IAQ), etc. These transmitters are equipped with a hotwire sensor, in the directional or omnidirectional version. The HD403TS... series of transmitters have a 4...20mA output, while the HD4V3TS... series have a 0...10Vdc output.

Two measuring ranges are available: 0.20...40m/s for ...S1 and ...S3 models with directional probe and 0.1...5.00m/s for ...S2 and ...S4 models with omnidirectional probe.

| Technical specifications                       |                   | Notes                  |
|--|-------------------|------------------------|
| Air speed                                      | 0.1...5.00m/s     | ...S2 and ...S4 models |
| Standard measuring range                       | 0.20...40.0m/s    | ...S1 and ...S3 models |
| Measurement accuracy                           | ±(0.2m/s+3%f.s.)  |                        |
| Response time (integration) selected by jumper | 0.2s<br>2.0s      | Fast<br>Slow           |
| Operating temperature electronics              | 0...+60°C         |                        |
| probe  | 0...+80°C         |                        |
| Compensation temperature                       | 0...+80°C         |                        |
| Storage temperature                            | -10...+80°C       |                        |
| Electronics protection class                   | IP67              |                        |
| Sensor working conditions                      | Clean air, RH<80% |                        |
| Case dimensions                                | 58x65x35          | Without probe          |
| Standard cable length                          | 2m                |                        |

| Model      | Output    | Power supply        | Load resistance   |
|------------|-----------|---------------------|-------------------|
| HD403TS... | 4...20mA  | 12...40Vdc or 24Vac | $R_L < 500\Omega$ |
| HD4V3TS... | 0...10Vdc | 16...40Vdc or 24Vac | $R_L > 10k\Omega$ |

### Installation notes

- The probe must be used with clean air only and humidity below 80%.
- In ...S1 and ...S3 directional probes, the sensor hole must be oriented in the same direction as the flow: turn the probe so that the displayed speed will be the highest, at constant flow.
- To fix the probe of ...S1, ...S2 and ...S3 models inside a ventilation duct, a pipe, etc. use a PG9 or PG11 metal cable gland according to the shape or a connection equipped with a 1/4" rubber ring.

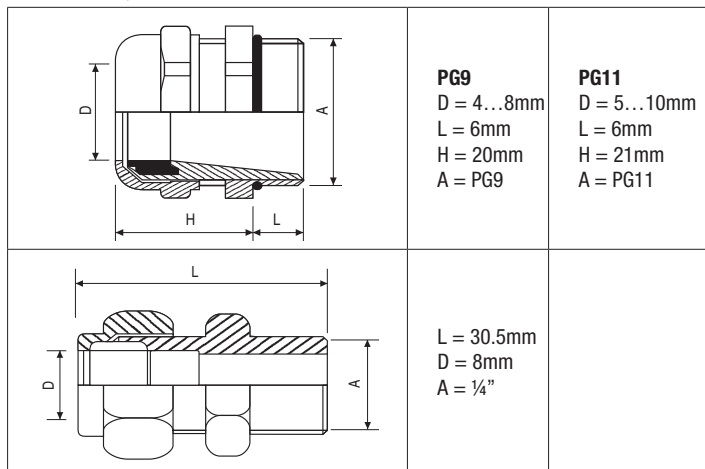

- The transmitters are factory calibrated and no further adjustments are required.
- Select the **response time** by using the JP jumper: in the FAST position, the response time is 0.2s, in the SLOW position is 2s. Set the jumper on SLOW in case of turbulence, otherwise please select the FAST position.

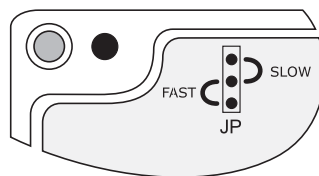

### Electrical connections

#### Power supply and output

Power the instrument at the voltage shown in the electrical specifications: power supply terminals are marked as +Vcc and GND. The output signal comes from VEL and GND terminals. To make the connection, please use a three-wire cable as shown in the drawing below.

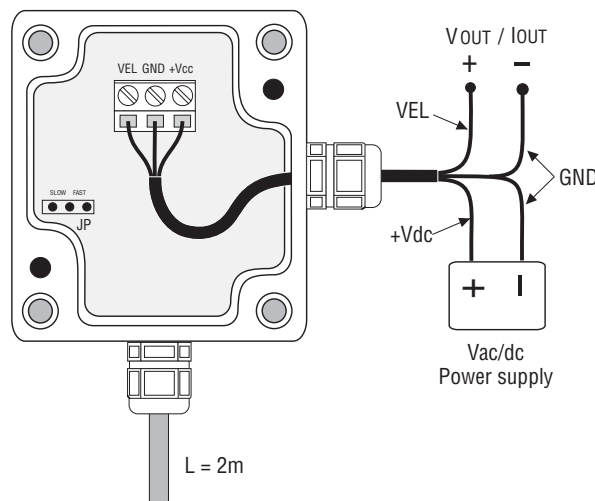

### Probe dimensions

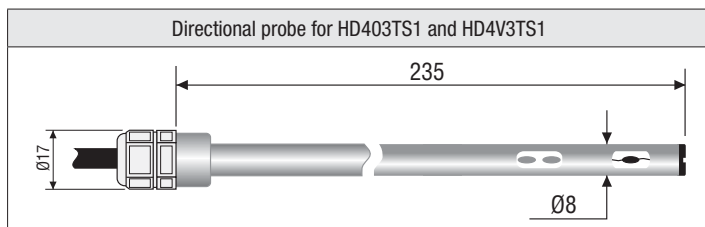

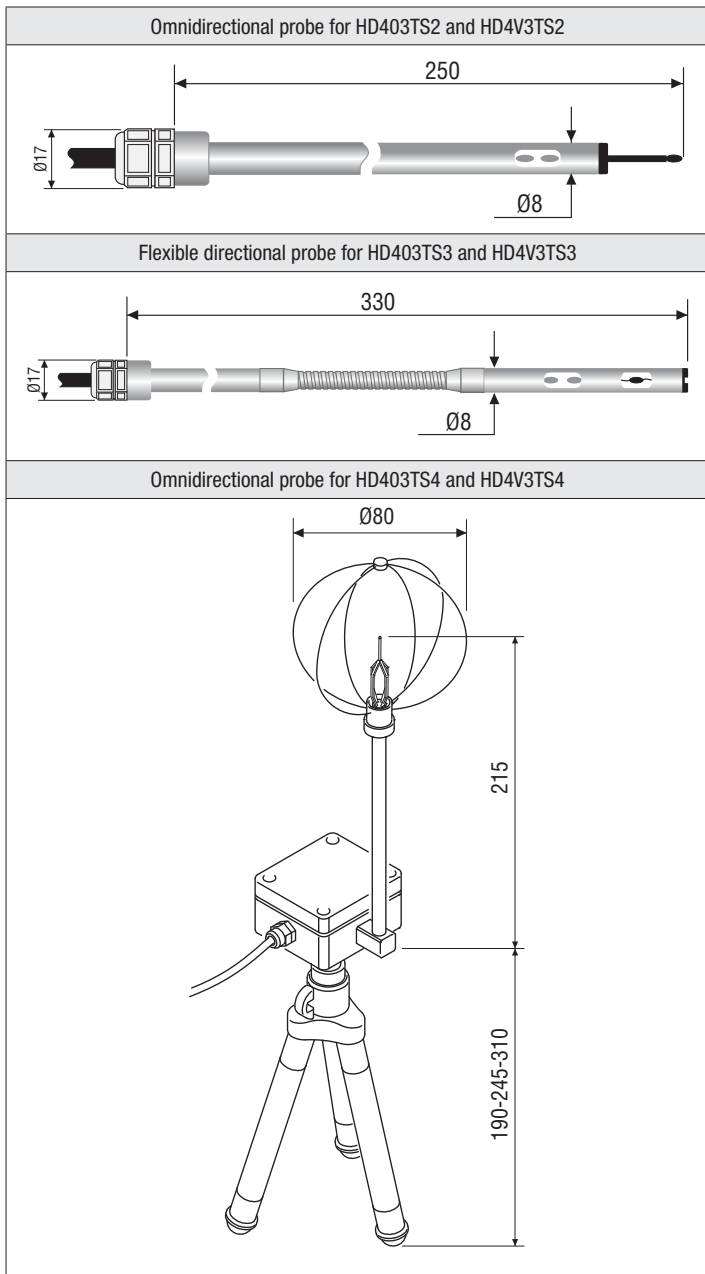

**ORDERING CODES**

**HD403TS1:** Active hotwire air speed transmitter with 4...20mA output. Measuring range: 0.20...40m/s. Directional probe Ø=8mm, cable L=2m.

**HD4V3TS1:** Active hotwire air speed transmitter with 0...10Vdc output. Measuring range: 0.20...40m/s. Directional probe Ø=8mm, cable L=2m.

**HD403TS2:** Active hotwire air speed transmitter with 4...20mA output. Measuring range: 0.1...5.00m/s. Omnidirectional probe Ø=8mm, cable L=2m.

**HD4V3TS2:** Active hotwire air speed transmitter with 0...10Vdc output. Measuring range: 0.1...5.00m/s. Omnidirectional probe Ø=8mm, cable L=2m.

**HD403TS3:** Active hotwire air speed transmitter with 4...20mA output. Measuring range: 0.20...40m/s. Flexible directional probe, Ø=8mm, cable L=2m.

**HD4V3TS3:** Active hotwire air speed transmitter with 0...10Vdc output. Measuring range: 0.20...40m/s. Flexible directional probe, Ø=8mm, cable L=2m.

**HD403TS4:** Active hotwire air speed transmitter with 4...20mA output. Measuring range: 0.1...5.00m/s. Omnidirectional probe with wired protective cover Ø=80mm. Equipped with tripod.

**HD4V3TS4:** Active hotwire air speed transmitter with 0...10Vdc output. Measuring range: 0.1...5.00m/s. Omnidirectional probe with wired protective cover Ø=80mm. Equipped with tripod.

**How to compose your purchasing code**

HD4  1  3 TS

- 1 = Directional probe
- 2 = Omnidirectional probe
- 3 = Flexible directional probe
- 4 = Omnidirectional probe with tripod

- 0 = 4...20mA signal output
- V = 0...10Vdc signal output



**Dimensions**

